



Uponor

PLUMBING
SYSTEMS

INSTALLATION GUIDE

Uponor Professional Plumbing Installation Guide



Table of Contents

Section 1: The Uponor Plumbing System	1
Applications	1
Ratings, Standards, Listings and Codes	1
Ratings	1
Standards	2
Listings	2
Codes	2
Tubing Identification	3
Fire-resistant Standards	4
Firestop Listings	4
Applications	4
Recirculation Systems	4
Uponor Residential Fire Safety Systems	4
Combined Potable-water and Hydronic-heating Systems	4
Section 2: Working with Uponor PEX Tubing	5
General Storing and Handling of PEX Tubing	5
Uncoiling PEX Tubing	5
Bending	5
Reforming Kinked Uponor AquaPEX® Tubing	5
Thawing Frozen Tubing	5
PEX Handling Guidelines for use in Hot- and Cold-water Distribution Systems	6
Section 3: ProPEX® Fitting System	7
Getting Started	7
Tools and Parts Required	7
General Information	7
Recommended Tubing Length	8
Using the ProPEX Hand Expander Tool	8
ProPEX Rings with Integral Stops	8
The Importance of Correct Expansion	8
Making ProPEX Connections	9
Important Tips for a Proper ProPEX Connection	11
Making 3/8" ProPEX Connections	11
Important Tips for a Proper 3/8" ProPEX Connection	11
Disconnecting a ProPEX Brass Fitting	11
Troubleshooting ProPEX Connections	12
For Fittings That Will Not Seal	12
If Expansion is Difficult	12
If the Expansion Head Slips out of the Tubing When Making Expansions	12
If the ProPEX Ring Slides Down the Tubing During Expansion	12
If More Than the Recommended Number of Expansions are Needed to Make a Connection	12
Cold-weather Expansions	12
Proper Expander Tool and Head Maintenance	12
Handling Guidelines For Engineered Plastic (EP) Fittings	13

Section 4: Water Service Phase 15

Handling and Repairs	15
Trench Bottom Preparation	15
Good Soil Conditions	15
Bad Soil Conditions	16
Installation	16
Joining Methods and Fittings	16
Tubing Embedment	17
Water System Disinfection	17

Section 5: Ground and Top-out Stage of Installation 19

Parts Inspection	19
Installing Uponor AquaPEX Tubing During Ground Work	19
Termiticide or Pesticide Treatment	20
Installing Uponor AquaPEX Tubing in Frame Construction	21
Tubing Runs	21
Recessed Lighting	21
Tubing Supports: General Guidelines	21
Tubing Supports: Horizontal Runs	22
Tubing Supports: Vertical Runs	22
Multi-port Tee, Multi-port Elbow and Manifold Placement	22
Common Components	22
Bend Supports	22
Drop Ear Bend Supports	23
ProPEX Out-of-the-Wall Support System	23
Drop Ear Elbows	24
Metal Straight-through Supports	24
Steel-plate Protectors	24
Water Hammer Arrestors	24
Shower Valve Connections	24
ProPEX Copper Tub Ells	25
ProPEX Copper Stub Ells	25
Hose Bibs	25
Pressure Testing the System	25
Back-draining the System	25
Washing Machine Outlet Box	26
Ice Maker Outlet Box	26

Section 6: Final Stage of Installation 27

Straight and Angle Stop Valves	27
EP Valves	27
Chrome Plated Brass Compression Stop Valves (Straight and Angle)	27
Uponor AquaPEX Risers	28
Lav Risers	28
Closet Risers	28

Section 7: Plumbing Inspector Checklist. 29
Tubing, Fittings and Valves 29
Tubing Limitations 29
Joints and Connections 29
ProPEX Fittings 29
Tubing Supports 29
General Recommendations 29
Pressure Testing. 30

This installation guide is published for building officials, plumbing professionals and contractors interested in Uponor professional plumbing systems. This manual describes general installation recommendations that use Uponor AquaPEX® tubing¹ products. Local code requirements should be followed.

Note: The Uponor plumbing system can include Uponor AquaPEX White, Blue or Red tubing as well as AquaPEX Reclaimed Water (purple) tubing, Pre-sleeved AquaPEX tubing and Pre-insulated AquaPEX tubing. For readability, this document will refer to Uponor AquaPEX tubing when information applies to any or all forms of Uponor AquaPEX tubing.

Uponor has used reasonable efforts in collecting, preparing and providing quality information and material in this manual. However, system enhancements may result in modification of features or specifications without notice. For the most current technical information, go to the Uponor website at www.uponorpro.com.

Uponor is not liable for installation practices that deviate from this manual or are not acceptable practices within the mechanical trades. Refer to the Uponor Residential Fire Safety System Installation Guide to install Uponor AquaPEX tubing in Uponor Fire Safety Systems.

Please direct any questions regarding the suitability of an application or a specific design to your local Uponor representative. For the name of your local representative, please call toll free 800.321.4739.

¹Uponor AquaPEX® tubing is a registered trademark of Uponor, Inc. and Uponor Ltd. ProPEX® is a registered trademark of Uponor, Inc. ProPEX™ is a trademark of Uponor Ltd.

Section 1

The Uponor Plumbing System

The Uponor Plumbing System consists of the following Uponor PEX tubing and Uponor plumbing components:

- Uponor AquaPEX® Red, White and Blue tubing
- AquaPEX Reclaimed Water (purple) tubing
- Pre-insulated Uponor AquaPEX tubing
- Pre-sleeved Uponor AquaPEX tubing
- ProPEX® Engineered Plastic (EP) Fittings
- ProPEX Brass Fittings
- ProPEX Lead-free Brass Fittings
- ProPEX Multiports
- Manifolds
- Supports
- Finishes

PEX is an acronym for crosslinked polyethylene. The PE refers to the raw material used to make PEX (polyethylene), and the X refers to crosslinking the polyethylene across its molecular chains. The molecular chains are linked into a three-dimensional network that makes PEX remarkably durable within a wide range of temperatures and pressures.

Uponor manufactures PEX tubing using the Engel method, a hot-crosslinking process. The actual crosslinking takes place during the extrusion process when the base polyethylene is above its crystal-melting temperatures. Classified within the industry as PEX-a tubing, Engel-method PEX is superior to other types of PEX — resulting in consistent, uniform and evenly crosslinked PEX. Uponor AquaPEX also demonstrates a great resistance to chemical-dissolving agents. This unique structure is stable and inert, and it is unaffected by chemicals commonly found in plumbing and heating systems. Uponor AquaPEX tubing is reliable, used in plumbing systems around the world for more than 30 years — longer than any other flexible plumbing system on the market.

Applications

Uponor AquaPEX tubing is versatile and has a broad range of uses:

- Potable Hot- and Cold-water Distribution
- Water Service
- Radiant Cooling
- Hydronic Radiant Heating (radiant floor, ceiling, baseboard and radiator connections)
- Snow and Ice Melting Systems
- Turf Conditioning Systems
- Fire Protection Systems
- Water Reclamation Systems

Ratings, Standards, Listings and Codes

Our extensive listings and history of system testing ensures you that Uponor AquaPEX tubing is suitable for use in many types of residential and commercial structures, including, but not limited to the following:

- Homes
- Townhomes
- Schools
- Daycare Centers
- Theatres
- Churches
- Nursing Homes
- Hotels
- Restaurant
- Gymnasiums
- Hospitals
- Apartments

Ratings

Uponor AquaPEX tubing has standard grade hydrostatic stress and pressure ratings in accordance with all four temperatures and pressures listed in Table 1 of ASTM F876. Uponor AquaPEX tubing is tested in accordance with Plastics Pipe Institute (PPI) TR-3 and is listed in PPI TR-4. The Standard Grade hydrostatic ratings are:

- 200°F/93.3°C at 80 psi
- 180°F/82.2°C at 100 psi
- 73.4°F/23°C at 160 psi

The Hydrostatic Stress Board of PPI issues these pressure and temperature ratings. Uponor AquaPEX White tubing has an additional rating of 120°F/48.9°C at 130 psi in accordance with UL1821 for ½", ¾" and 1" tubing used in multipurpose fire protection systems.

Standards

Uponor AquaPEX tubing, ProPEX EP fittings, ProPEX brass fittings, EP multiport products, EP valves and copper-valved manifolds are manufactured and tested to the standards listed in **Table 1-1**.

Standard	Specification
ASTM F876	Standard Specification for Crosslinked Polyethylene (PEX) Tubing
ASTM F877	Standard Specification for Crosslinked Polyethylene (PEX) Plastic Hot- and Cold-Water Distribution Systems
ASTM F2023	Standard Test Method for Evaluating the Oxidative Resistance of Crosslinked Polyethylene (PEX) Tubing and Systems to Hot Chlorinated Water
ASTM F1960	Standard Specification for Cold Expansion Fittings with PEX Reinforcing Rings for Use with Crosslinked Polyethylene (PEX) Tubing
ANSI/NSF Standard 14	Plastics Piping System Components and Related Materials
ANSI/NSF Standard 61	Drinking Water System Components — Health Effects
UL 1821	Thermoplastic Sprinkler Pipe & Fittings for Fire Protection Service (½", ¾" and 1" Uponor AquaPEX White only)
ANSI/AWWA C904	Cross-linked Polyethylene (PEX) Pressure Pipe, ½" (12 mm) through 3" (76 mm) for Water Service
CAN/CSA B137.5	The Canadian Standards Association Standard CAN/CSA B137.5, Crosslinked Polyethylene (PEX) Tubing Systems For Pressure Applications
ULC-ORD-C199P	Combustible Piping for Sprinkler Systems

Table 1-1: Standards

Listings

Uponor AquaPEX is listed with the following agencies:

- ANSI/NSF (14- and 61-certified)
- International Code Council (ICC)
- International Association of Plumbing and Mechanical Officials (IAPMO)
- U.S. Department of Housing and Urban Development (HUD)
- Canadian Standards Association (CSA)
- Intertek Testing Services (ITS/Warnock Hersey)
- Underwriters Laboratories (UL)
- Plastics Pipe Institute (PPI)/Hydrostatic Stress Board (HSB)

Uponor AquaPEX is listed in the following model codes for water service:

- IPC
- UPC
- NSPC
- NPC of Canada

Note: Check with your local Uponor representative for code compliance in your area.



Codes

Uponor AquaPEX listed to ASTM F876 and F877 is approved in the following model codes for water distribution.

- International Plumbing Code (IPC)
- Uniform Plumbing Code (UPC)
- National Standard Plumbing Code (NSPC)
- National Plumbing Code of Canada (NPC of Canada)

Tubing Identification





The labeling (print line) on Uponor AquaPEX tubing provides several identifications. For example, Uponor AquaPEX ½" tubing reads as follows:

Uponor AquaPEX® PEX 5006 ½ IN SDR9/
 B137.5 POTABLE /  130PSI 120°F (49°C)
 UL1821/ULC-ORD C199P¹ ( ASTM F876/
 F877/F2023)

(ASTM F1960/F2080 ) /ICC ESR-1099/
 ICC ESR1529/HUD

MR1269d (WHI-LISTED CAN/US FS25/SD50)/
 160PSI 73.4°F (23°C)/100PSI 180°F (82°C)/
 80PSI 200°F (93°C)

200°F (93°C) UPONOR PEX-a TUBING UN04950127²
 xxxxx³

Print Stream on Tubing	Explanation
UPONOR AquaPEX	Brand Name
PEX 5006	ASTM F2023 Testing I/A/W ASTM F876
½ IN	Tubing Size (Example: ½")
SDR9	Standard Dimensional Ratio of 9
 B137.5 POTABLE	Potable Water Listing by CSA
 130PSI 120° F (49° C) UL1821	Rating I/A/W UL 1821 (½", ¾" and 1" only)
ULC-ORD C199P ¹	Canadian Rating I/A/W UL1821 and C199P
 ASTM F876/F877/F2023	ASTM Tubing Standards Listed by NSF
ASTM F1960/F2080/F1807	ASTM Fitting Standards Listed by NSF
	IAPMO Reports 3558, 3960
ICC ESR-1099	ICC Evaluation Services Report ESR-1099
ICC ESR1529	ICC Evaluation Services Report ESR 1529
HUD MR1269d	HUD Material Release Report 1269d
WHI-LISTED CAN/US FS25/SD50	Warnock Hersey Listing for 25/50 Plenum Rating
160PSI 73.4°F (23°C)/100PSI 180°F (82°C)/80PSI 200°F (93°C)	Hydrostatic Ratings from PPI in Accordance with ASTM F876
UPONOR PEX-a TUBING	Type of Crosslinking (PEX-a)
UN04950127 ²	Manufacturing Code to Audit Material Source
xxxxx ³	Footage Marker in Increments of 3' (three feet)

¹ For ½-inch tubing only

² USA, Material Type, Extruder No., Year, Month, Day

³ Footage marking in increments of three feet (3')

Table 1-2: Print Stream Identification

Fire-resistant Standards

For a complete list of the fire-resistant standards, codes and listings, refer to the Uponor Plumbing Design Assistance Manual (PDAM).

Firestop Listings

Numerous firestop manufacturers have tested their products with PEX tubing. These tests establish the installation procedures for installing the firestop around PEX tubing at the penetration. The type of penetration (e.g., wall, floor or ceiling) determines how these test assembly sections are divided.

Not all caulks are approved for all penetrations. Make sure you seal the penetration in accordance with the appropriate test assembly, using the type of firestop material recommended by the manufacturer. Larger penetrations may not allow the use of some caulk type of firestop — a wrap or collar assembly may be required. Refer to the respective firestop manufacturer for more information on appropriate applications of their products.

Current firestop products that are compatible with Uponor AquaPEX tubing include:

- RectorSeal Metacaulk Intumescent Firestop
- Nuco Selfseal GG-266 Firestop
- 3M Fire Barrier IC 15WB+ Sealant
- Hilti FS-1 Fire Caulking

These products, based on their chemical composition, were tested and found to be compatible with Uponor AquaPEX tubing. There are numerous other firestop products available on the market that may be compatible with Uponor AquaPEX, though some have not gone through the Uponor verification process. If there are other firestop products you would like reviewed for compatibility, please contact Uponor at 800.321.4739.

Applications

Recirculation Systems

Based on our extensive history of use and testing, Uponor provides the following guidelines for using Uponor PEX tubing and corresponding fitting systems in recirculating systems.

- Uponor AquaPEX is suitable for use in:
 - o Recirculation systems operating up to 140°F (60°C)
 - o Timed, sensor-activated or self-activated recirculation systems operating at temperatures not exceeding 140°F (60°C)
 - o Continuous recirculation systems operating at temperatures not exceeding 140°F (60°C)

Note: Uponor does not promote the use of continuous recirculation due to excessive energy waste.

- The tubing is marked with the following designation as required by the most recent edition of ASTM F876: PEX 5006. The first digit indicates chlorine-resistance testing (“5” means compliance with ASTM F876, Chlorine-resistance Testing for Continuous Recirculating Systems).
- Do not exceed the published temperature and pressure ratings of the tubing.
- Using recirculation systems may increase the risk of scalding. Therefore, Uponor recommends limiting the delivered water temperature to 120°F (49°C) in all cases.

Uponor Residential Fire Safety Systems

The Uponor Residential Fire Safety system is a residential fire protection system installed in combination with the cold side of the domestic potable water system. Only licensed contractors trained by Uponor can install this system. Contact your local Uponor representative for more information about training certification and project support for the Uponor Residential Fire Safety system.

Combined Potable-water and Hydronic-heating Systems

Uponor AquaPEX can be used in combined potable water and hydronic heating systems where allowed by code. Depending on the heating-control strategy employed, these systems typically do not exceed 140°F (60°C). If the system water temperature will exceed 140°F (60°C), the installing contractor is responsible for providing anti-scald devices to protect the inhabitants. In addition, the installer must ensure, and is responsible for, providing weekly off-season (summer) circulation through the heating portion of the system to prevent water stagnation.

Contact your local plumbing and heating code official to see if code allows these combined systems in your area. If allowed within your area, be sure to complete a proper heat-loss and design plan that takes into account the loss of heat energy between the two systems. It is advisable to have a clear knowledge of the resulting impact on the performance of each of these systems prior to installation.

Section 2:

Working with Uponor PEX Tubing

General Storing and Handling of PEX Tubing

- Do not store PEX tubing outdoors.
- Keep PEX tubing in the original packaging until you are ready to install.
- Ensure that exposure to sunlight during installation does not exceed the maximum recommended UV exposure time of 30 days.

Uncoiling PEX Tubing

We recommend using one of the following Uponor uncoilers to facilitate convenient uncoiling of PEX tubing:

- Uponor Select Uncoiler (E6062000)
- Uponor Compact Select Uncoiler (E6063000)
- Uponor Tube Uncoiler (E6061000)

If one is not available, construct a suitable uncoiler.

Bending PEX Tubing

The minimum bend radius of Uponor AquaPEX tubing in any direction is six times the outside diameter (6 x OD).

Bend supports are available for $\frac{3}{8}$ ", $\frac{1}{2}$ ", $\frac{3}{4}$ " and 1" Uponor AquaPEX tubing to facilitate 90-degree rigid bends.

Reforming Kinked Uponor AquaPEX Tubing

For kinked tubing that hinders flow, repair as follows:

1. Ensure that the system is not pressurized.
2. Straighten the kinked portion of the tubing.
3. Heat the kinked area to approximately 265°F (129.4°C) with an electric heat gun (approximately 450 watts of power). Apply the heat evenly until the tubing returns to its original size and shape. Do not use an open flame.



Caution: Do not allow the temperature of the tubing surface to exceed 338°F (170°C). Do not apply direct flame to Uponor AquaPEX tubing.

4. Let the repaired Uponor AquaPEX tubing cool undisturbed to room temperature. When the tubing returns to its opaque appearance, the repair is complete.

Uponor AquaPEX tubing repaired according to these recommendations will return to its original shape and strength. If Uponor AquaPEX tubing is sliced, punctured or otherwise damaged beyond the capacity of the crosslinked memory, it is necessary to install a coupling. Crosslinked polyethylene cannot be welded or repaired with adhesives.

Note: You may temporarily affix adhesive tape to PEX tubing or EP fittings during installation. However, to protect the integrity of the system, the tape should not be permanent. Remove the tape and residual adhesive after completing the installation.

Thawing Frozen Tubing

Uponor AquaPEX tubing exceeds other tubing and piping in its ability to withstand extreme freeze/thaw cycles. The crosslinked structure of the tubing allows it to expand and absorb much of the expansion energy from the freezing process. No tubing product is freeze-proof, but Uponor AquaPEX tubing is extremely resistant to freeze damage.

If freezing occurs, the contractor should advise the end-user to correct the lack of insulation or heat to eliminate the possibility of future problems.

If the tubing experiences an ice blockage, thaw the tubing as follows:

1. Pour hot water over the affected tubing area.
2. Wrap hot towels around the affected tubing area.
3. Place a small, portable heating device in the area to heat the space and thaw the ice blockage from the tubing.
4. Slowly heat the affected area of the tubing with a heat gun. Rub your hand over the area while heating the tubing to ensure the tubing does not get too hot.
5. Use a commercial system that pumps hot water to the ice blockage and returns the cooled water to be re-heated.

PEX Handling Guidelines for use in Hot- and Cold-water Distribution Systems

The following highlights the most common guidelines for installing Uponor PEX tubing in water distribution systems. For applications other than water distribution systems, refer to the appropriate Uponor manuals or contact your Uponor representative:

- Install Uponor systems according to the installation instructions of the manufacturer. Failure to follow the instructions and installation guidelines can result in system function failure.
 - Do not use PEX tubing where temperatures and pressures exceed ratings.
 - Do not expose PEX tubing to direct sunlight for more than 30 days.
 - Do not weld, glue or use adhesives or adhesive tape on PEX tubing.¹
 - Do not apply open flame to PEX tubing.
 - Do not install PEX tubing within 6" of any gas appliance vents, with the exception of double-wall B-vents or plastic vents, which have a minimum clearance of 1".
 - Do not install PEX tubing within the first 18" of a connection to a water heater, unless otherwise allowed by code. Follow your local code requirements.
 - Do not install PEX within 12" of any recessed light fixtures, unless the PEX tubing is protected with suitable insulation.
 - Do not solder within 18" of any PEX tubing in the same water line. Make all sweat connections prior to making the fitting connection.
 - Do not install PEX tubing between the tub/shower valve and tub spout.
 - Do not use PEX tubing for an electrical ground.
 - Do not spray on or allow any organic chemicals, pesticides, strong acids or strong bases to be exposed to PEX tubing.
 - Do not use petroleum or solvent-based paints on PEX tubing.
 - Use only approved and appropriate firestop materials with PEX tubing.
 - Although PEX tubing does not attract rodents, pests and other insects, these uninvited guests can have detrimental effects on PEX system integrity as well as duct systems, electrical systems and other integrated systems in a home. Property owners should take steps to eliminate pests.
- Do not subject PEX tubing to impact.
 - During remodeling or ceiling repair, take appropriate precautions to protect the tubing from damage.
 - Do not install PEX tubing in direct view of florescent lighting.

¹ You may temporarily affix adhesive tape to Uponor PEX tubing during installation. However, to protect the integrity of the system, the tape should not be permanent. Remove the tape and residual adhesive after completing the installation.

Section 3:

ProPEX® Fitting System

Uponor ProPEX® fittings, manufactured to ASTM F1960, are designed for Uponor AquaPEX tubing. Uponor offers ProPEX fittings made from EP, brass, lead-free brass or stainless steel. All are NSF 61-certified.

Getting Started

This section provides the information you need to make strong, reliable connections using the ProPEX fitting system. It is important to read the contents of this section completely and ensure that you have all of the required materials and tools before beginning this process. If you have questions, contact your local Uponor representative. This section covers the following topics:

- General Information
- Making ProPEX Connections
- Important Tips for a Proper ProPEX Connection
- Making 3/8" ProPEX Connections
- Important Tips for a Proper 3/8" ProPEX Connection
- Disconnecting a ProPEX Brass Fitting
- Troubleshooting
 - o Troubleshooting ProPEX Connections
 - o For Fittings that Will Not Seal
 - o If Expansion is Difficult
 - o If the Expansion Head Slips Out of the Tubing When Making Expansions
 - o If the ProPEX Ring Slides Down the Tubing During Expansion
 - o If More Than Recommended Number of Expansions are Needed for a Connection
- Cold-weather Expansions
- Proper Expander Tool and Head Maintenance
- Handling Guidelines for EP Fittings

Tools and Parts Required

- ProPEX Expander Tool¹
- ProPEX Ring(s)
- ProPEX Fitting(s)
- Uponor AquaPEX Tubing

¹The Uponor ProPEX Expander Tool is available in several types. You can use the ProPEX Hand, Battery, Air or Corded Expander tools. The steps are the same for these tools, with a slight variation in step 3 that only applies to the ProPEX Hand Expander Tool as noted in step 3 on **page 9**. Refer to the Uponor Product Catalog for a description (features and benefits) of these products.

General Information

This section includes the following basic information:

- Recommended Tubing Length (between ProPEX fittings)
- Using the ProPEX Hand Expander Tool
- ProPEX Rings with Integral Stops
- The Importance of Correct Expansion

Recommended Tubing Length

Use an adequate length of tubing between two ProPEX fittings. The minimum allowed tubing length varies by fitting size as defined in **Table 3-1**.

Fitting Size	Minimum Tubing Length
3/8" ProPEX Fitting	2"
1/2" ProPEX Fitting	2 1/2"
3/4" ProPEX Fitting	3 1/2"
1" ProPEX Fitting	4 1/2"
1 1/4" ProPEX Fitting	5 1/2"
1 1/2" ProPEX Fitting	6 1/2"
2" ProPEX Fitting	7 1/2"

Table 3-1: Minimum Tubing Length

Using the ProPEX Hand Expander Tool

Prior to use, ensure that you perform proper lubrication of the ProPEX Hand Expander Tool (Q6275075) — refer to **Making ProPEX Connections** in this section. When using the expander tool, brace the free handle of the tool against your hip or place one hand on each handle. Fully separate the handles and slide the expander head into the tubing until it stops. For proper connections, it is critical to make full expansions.

Once expanded, separate the handles and remove the head from the tubing. If you are not using the ProPEX Auto Rotation Adapter (Q6323810), then you must manually rotate it one-eighth (1/8) turn in either direction. The Auto Rotation Adapter will automatically rotate the expander head after each expansion. Slide the tool head into the tubing in the newly rotated position and expand again, as required.

ProPEX Rings with Integral Stops

A ProPEX Ring is required to make a ProPEX connection. The ProPEX 1/2" and 3/4" rings now include a leading edge chamfer and integral stop edge to simplify the use of ProPEX fittings.

The Importance of Correct Expansion

It is important to make strong, reliable connections. Correct expansion procedures are critical in preventing leaks. Make connections by sliding a ProPEX Ring over the PEX tubing and expanding them simultaneously. The expanded tubing and ProPEX Ring then slide over the fitting. The connection occurs as the PEX tubing shrinks over the fitting because of the unique shape memory of Uponor AquaPEX. Please read the following directions completely before you begin.

Making ProPEX Connections

The following steps illustrate how to make proper connections using a ProPEX expander tool.

1. Lightly grease the cone of the ProPEX Expander Tool (manual, air, corded or battery).
2. If using an auto rotation adapter, snugly thread the ProPEX Auto Rotation Adapter (Q6323810) onto the tool. Remove excess oil from the adapter cone, and then lightly grease the cone of the adapter.



Caution: Lack of grease may cause the expander to lock in the open position. If the expander locks open, unscrew the head and apply grease to the adapter cone.

3. Select the proper expander head (see **Table 3-2** on **page 10** for reference).

Note: H-heads are not compatible with the ProPEX Hand Expander (Q6275075) or the ProPEX Auto Rotation Adapter (Q6323810).

4. Thread the proper expander head onto the ProPEX Expander Tool or the ProPEX Auto Rotation Adapter.¹

¹ The ProPEX Auto Rotation Adapter expands $\frac{3}{8}$ " through 1" tubing, fits on all ProPEX expander tools — manual, air, corded and battery, except for the ProPEX 200 Battery Expander Tool (Q6262000). It is compatible with all standard expander heads except H-heads.

Note: When using the ProPEX Auto Rotation Adapter (Q6323810), open and close the expander tool a few times to engage the auto-rotation feature prior to tube expansion (see **Figure 3-3**).

5. Square-cut the PEX tubing perpendicular to the length of the tubing (see **Figure 3-4**).
6. Slide the ProPEX Ring over the end of the tubing as shown in **Figure 3-5**. Extend the end of the ring over the end of the tubing no more than $\frac{1}{16}$ " (1.6mm). When using a ProPEX Ring with a stop edge, slide the ring onto the tubing end until it hits the stop.
7. Gently slide the expander head into the tubing until it stops (see **Figure 3-6**).

Important: Do not force the expander head into the tubing.

8. Close the handles of the manual tool or press the trigger of the power tool to expand. Open the handle (manual tool) or release the trigger (power tool) and remove the expander tool from the tubing, then rotate the expander head one-eighth ($\frac{1}{8}$) of a turn. (**Note:** The Auto Rotation Adapter rotates the expander head automatically.) Reinsert the tool into the tubing for the next expansion. Refer to **Table 3-2** for the recommended number of expansions required for your tubing size.



Figure 3-1: ProPEX Expander Tool

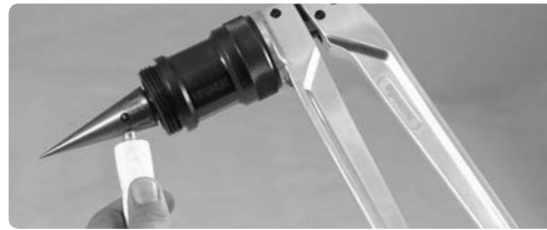

Figure 3-2: ProPEX Expander Tool Preparation



Figure 3-3: Operate Expander Tool to Rotate Adapter



Figure 3-4: Square-cut the PEX Tubing



Figure 3-5: Place ProPEX Ring on Tubing



Figure 3-6: Insert Expander Head into Tubing

Important: Rotation of the expander head in either direction after EVERY expansion is necessary to provide smooth and even expansion of the tubing. If using the Auto Rotation Adapter, manual rotation of the expander head is not necessary. See **Figure 3-7** for a view of tubing when proper rotation is accomplished.

Note: When not using the Auto Rotation Adapter, it is not necessary to rotate the tool in only one direction. Alternating the turning direction will ease expansion in confined spaces.

If you fail to reposition the head after each expansion, the segments of the tool head may cause deep grooves in the tubing, which could result in potential leak paths. See **Figure 3-8** for a view of tubing resulting from improper rotation.

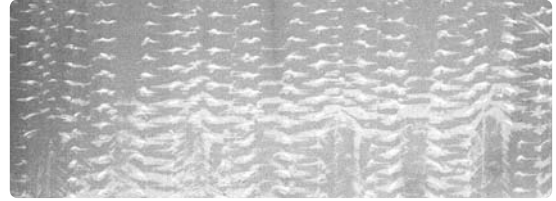

Figure 3-7: Expansion with Proper Rotation

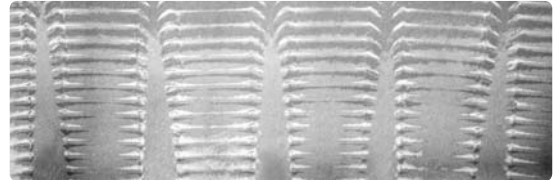

Figure 3-8: Expansion without Proper Rotation

Table 3-2 provides the recommended range of expansions needed for various tubing sizes depending on the expander tool used (manual, air, corded or battery).

Tubing Size	Ring Marking	Head Marking			Number of Expansions		
		Manual	Air	Corded or Battery	Manual	Air	Corded or Battery
3/8"	3/8"	3/8"	3/8"	3/8"	4-5	4-5	6-7
1/2"	1/2"	1/2"	1/2"	1/2"	3-4	3-4	3-4
3/4"	3/4"	3/4"	3/4"	3/4" H	7-9	7-9	8-9 H
1"	1"	1"	1"	1" H	12-14	12-14	6-7 H
1 1/4"	1 1/4"	—	—	1 1/4" H	—	—	6-7 H
1 1/2"	1 1/2"	—	—	1 1/2" H	—	—	7-8 H
2"	2"	—	—	2" H	—	—	4-5 H

Table 3-2: Range of Expansions Required

Note: The "H" in the chart refers to the H-series expander heads — used only with the ProPEX Battery and Corded Expander Tools. Only use the 2" H-series expander head on the ProPEX 200 Battery Expander Tool (Q6262000) or ProPEX 201 Corded Expander Tool (Q6272000).

9. Expansion is complete when the tubing and ring are snug against the shoulder on the expander head.
10. Immediately remove the ProPEX expander tool. You should feel resistance as you insert the fitting. The tubing and ProPEX ring should be set against the shoulder of the fitting for a proper connection.



Figure 3-9: Complete Expansion



Figure 3-10: Insert Fitting into Tubing

Important Tips for a Proper ProPEX Connection

- If the fitting does not slide into the tubing all the way to the stop, immediately remove it from the tubing and expand the tubing one final time.

Note: To avoid overly expanding the tubing, do not hold the tubing in the expanded position.

- **Table 3-2** indicates the recommended number of expansions for each tubing size. Experience, technique and weather conditions influence the actual number of expansions. Fewer expansions may be necessary under certain conditions. The correct number of expansions is the number necessary for the tubing and the ring to reach the shoulder of the expander head before the final expansion.
- Good connections result when the ProPEX Ring rests snugly against the stop of the ProPEX fitting shoulder. If there is more than $\frac{1}{16}$ " (1.6mm) between the ring and the shoulder of the fitting, square-cut the tubing 2" away from the fitting, and make a connection using a new ProPEX Ring.

Making $\frac{3}{8}$ " ProPEX Connections

The $\frac{3}{8}$ " ProPEX Ring is smaller and thicker than the rings used for other tubing sizes. To fit over the tubing properly, the $\frac{3}{8}$ " ProPEX Ring must be expanded once on each side. Expansion of the ProPEX Ring is only necessary for $\frac{3}{8}$ " Uponor AquaPEX.

1. Square-cut the $\frac{3}{8}$ " Uponor AquaPEX tubing perpendicular to the length of the tubing.
2. Expand each side of the $\frac{3}{8}$ " ProPEX Ring with the ProPEX Expander Tool once.
3. Slide the expanded $\frac{3}{8}$ " ProPEX Ring over the end of the tubing. Make sure the end of the ring extends over the end of the tubing no more than $\frac{1}{16}$ " (1.6mm).
4. When the $\frac{3}{8}$ " ProPEX Ring is properly expanded, gently slide the expander head onto the tubing until it stops (do not force).
5. Close the handles of the manual tool or press the trigger of the power tool to expand. Open the handle (manual tool) or release the trigger (power tool) and remove the expander tool from the tubing. Then rotate the expander head one-eighth ($\frac{1}{8}$) of a turn (**Note:** The Auto Rotation Adapter rotates the expander head automatically). Reinsert the tool into the tubing for the next expansion. Refer to **Table 3-2** on **page 10** for the recommended number of expansions required.

Note: If not using the Auto Rotation Adapter, rotate the expander head in either direction after EVERY expansion. This will ensure a smooth and even

expansion of the tubing. It is not necessary to rotate the tool in only one direction. Alternating the turning direction will ease expansion in confined spaces. It is important to reposition the head after each expansion.

Expansion is complete when the tubing and ring are snug against the shoulder on the expander head.

6. Immediately remove the ProPEX expander tool. You should feel resistance as you insert the fitting. The tubing and ProPEX Ring should be set against the shoulder of the fitting for a proper connection.

Important Tips for a Proper $\frac{3}{8}$ " ProPEX Connection

- When the temperature is above 40°F (4°C), ProPEX connections to $\frac{3}{8}$ " Uponor AquaPEX tubing require four to five expansions. When the temperature is below 40°F (4°C), only four expansions are necessary.
- The thicker $\frac{3}{8}$ " ProPEX Ring shrinks over the fitting faster than other sizes of rings.

Disconnecting a ProPEX Brass Fitting

ProPEX brass fittings are manufactured connections that the installer can conceal in walls, ceilings and floors. However, when necessary, the installer can disconnect ProPEX brass fittings. To disconnect a ProPEX brass fitting, use the following steps.

1. Turn off the supply valve and open faucets to drain the system and ensure that the system is not pressurized.
2. Use a heat gun to heat one side of the ProPEX Ring. When the ring is clear, use a utility knife and carefully cut through the ring parallel to the tubing to avoid cutting into the sealing barb of the fitting. Remove the ProPEX Ring from the tubing with pliers to avoid touching the hot ring.

Note: Do not gouge the fitting when cutting the ProPEX Ring. Nicks and gouges in the fitting could result in leaks. If gouged, discard the fitting.

3. When removing the ProPEX Ring, apply heat directly around the fitting and tubing connection. Gently work the tubing back and forth while pulling slightly away from the fitting until the tubing separates from the fitting.
4. After removing the tubing from the fitting, square-cut the tubing a minimum of 2" from the end of the tubing.

5. Use a new ProPEX Ring and follow the steps to make a new ProPEX connection. Allow the fitting to cool before attempting to make another connection.

Note: EP fittings cannot be reclaimed or reused.

Troubleshooting ProPEX Connections

Smooth ProPEX installations begin with a well-maintained ProPEX expander tool. If the tool has damaged conical or segment fingers, it is very difficult to make a proper connection. The following suggestions assist with troubleshooting in the field.

For Fittings That Will Not Seal

- Make sure that you have securely screwed the expander head onto the tool (hand-tightened).
- Examine the tool to ensure there are no bends in the segment fingers of the expander head. If the head does not completely close when the internal cone of the expander tool is fully retracted, replace the head.
- Examine the tool for excess grease on the internal cone or segment fingers of the expander head. Remove excess grease prior to making ProPEX connections.
- Examine the fitting for any damage. Sharp nicks and gouges on the fitting will cause the fitting to leak.
- Ensure the internal cone is not damaged or bent.
- Make sure the last expansion is not held in the expanded position before the fitting is inserted. The longer the tubing and ProPEX Ring are held in the expanded position, the greater the chance for a leak (due to over-expansion).
- If you are not using the ProPEX Auto Rotation Adapter, be sure to rotate the tool one-eighth ($\frac{1}{8}$) turn in either direction after each expansion.

If Expansion is Difficult

- Make sure the internal cone is properly greased.

If the Expansion Head Slips Out of the Tubing When Making Expansions

- Ensure the tubing and ProPEX Ring are dry.
- Make sure that grease is not getting into the tubing.
- Examine the segment fingers of the expander head to make sure there are no bends.

If the ProPEX Ring Slides Down the Tubing During Expansion

- Ensure your hands are clean while handling the tubing. Any sweat or oils on your hands can act as a lubricant. Due to the smoothness of PEX, any form of lubricant can cause the PEX Ring to slide across the tubing during expansion.

- If you anticipate any sliding, position the ProPEX Ring slightly more than $\frac{1}{16}$ " (1.6mm) over the end of the tubing and make the first few expansions slowly. Once the ring and the tubing begin to expand together, you can continue with the normal number and type of expansions.
- Place your thumb against the ProPEX Ring for support and feel for any movement. If caught early, you can slide the ring up the tubing and expand as described in the previous bullet point.

If More Than the Recommended Number of Expansions are Needed to Make a Connection

- Make sure that the head is hand-tightened to the expander tool.
- Examine the expander head to make sure that no segment fingers are bent.
- Be sure to completely cycle the tool on each expansion, (e.g., close the manual tool handle or release the trigger of the battery expander tool).

Cold-weather Expansions

- Temperature affects the time required for the tubing and ring to shrink onto the fitting. The colder the temperature, the slower will be the contraction time.
- Warming ProPEX fittings and ProPEX rings reduces contraction time. Put fittings and rings in your pockets or keep them in a warmed box prior to installation to keep them warm.
- ProPEX connections must be made at temperatures above 5°F (-15°C).
- Fewer expansions are necessary in temperatures below 40°F (4°C).

Proper Expander Tool and Head Maintenance

- ProPEX expander tools are sturdy, but you must handle with care to prevent possible damage to the cone and the expander heads.
- Remove and clean the segment fingers as needed.
- Remove the segments from the attachment ring by pushing the segment finger down toward the opening in the ring. Once you have removed the first segment, the rest follow easily.
- Place the segments on a flat surface with the ridges facing up. The fingers should lay flat without any curve in the middle. If the segments are bent, replace the head immediately.

- To reassemble, replace the segment fingers one at a time to the attachment ring by sliding the grooved portion of the segment fingers over the spring in the attachment ring. The narrow ends of the segment fingers point away from the solid side of the attachment ring. Hold these segment fingers in place with your thumb as you insert the remaining segment fingers.
- After cleaning and reassembling the expander head, use a lint-free cloth to apply a light coat of lubricant to the cone prior to making any ProPEX connections.
- If used regularly, apply the lubricant daily to the cone of the ProPEX Expander Tool (manual, air or battery) as well as the ProPEX Auto Rotation Adapter. Failure to keep these tools lubricated may result in improper connections.
- The handles of the ProPEX Hand Expander Tool will open and close smoothly if properly lubricated.



Caution: Excessive lubrication may result in improper connections. Only use a small amount of lubrication to keep the tool working properly.

- Keep all other parts of the tool free from lubricant.
- Once a month, soak the heads in degreasing agent to remove any grease from between the segments. Clean the cone using a clean, dry cloth.
- Store the tool and expander heads in the case. Store the tool with an expansion head in place to protect the cone. When storing the manual expander in its case, loosen expander head to ensure that the handles close completely. Remember to re-tighten the expander head before using the tool again.
- Store the tool in a dry location to prevent rust.
- Uponor offers the Tool Depot as a convenient way to service tools quickly and easily. For more information or for specific instruction on how to get your tool serviced, contact Uponor Technical Services toll free at 800.321.4739, or go to: https://extranet.uponor-usa.com/global_content/tooldepot/index.php.

Handling Guidelines for EP Fittings

The following highlights the most common guidelines for handling EP fittings:

- Do not solder within 18" of any EP fittings in the same water line. You must make sweat connections prior to making the ProPEX connection.
- Do not subject EP fittings to impact.
- Do not use adhesives or adhesive tape with EP fittings.
- Do not expose EP fittings to open flame.
- Do not expose solder, flux, pipe dope or solvents to EP fittings as immediate damage may result.
- When using urethane foam insulation/sealant, ensure that you cover the EP fittings with a protective (polyethylene, foil, etc.) sleeve to prevent direct contact between the urethane foam and the EP fittings.
- Never pull or drag tubing by the installed EP fittings.
- Do not expose EP fittings to excessive bending loads (greater than 100 lbs.).
- Do not use Uponor EP fittings where temperatures and pressures exceed ratings.
- Do not spray on or allow organic chemicals, strong acids or strong bases to contact Uponor EP fittings.
- Although EP fittings do not attract rodents, pests and other insects, these uninvited guests can have detrimental effects on EP fittings as well as duct systems, electrical systems and other integrated systems in a home. Property owners should take steps to eliminate pests.
- Do not use petroleum or solvent-based paints on Uponor EP fittings.

Section 4: Water Service Phase

Uponor AquaPEX tubing meets the requirements of the following standard:

- ANSI/AWWA Standard C904-06, Crosslinked Polyethylene (PEX) ½ inch (12mm) through 3 inches (76mm) for Water Service

Please refer to the ANSI/AWWA Standard for information regarding the selection, use and proper application of PEX tubing in water service.

Handling and Repairs

Although Uponor AquaPEX tubing is highly resistant to kinking and abrasion, it is important to handle with care while installing the tubing to prevent damage and possible failure. If damage occurs during installation, cut out and repair the area before backfilling.

To reform kinked tubing, refer to **Section 2: Reforming Kinked Uponor AquaPEX Tubing on page 5**. If damaged beyond the thermal memory capacity of the tubing, use a ProPEX repair coupling that is suitable for direct burial.

Note: Do not reuse or reclaim EP fittings.

Trench Bottom Preparation

For a successful installation, the supporting soil must provide a stable and continuous support for the tubing.

Good Soil Conditions

If the trench cut is relatively smooth, install the tubing directly on the prepared bottom. The bottom must be flat with no hollows, lumps or rocks.

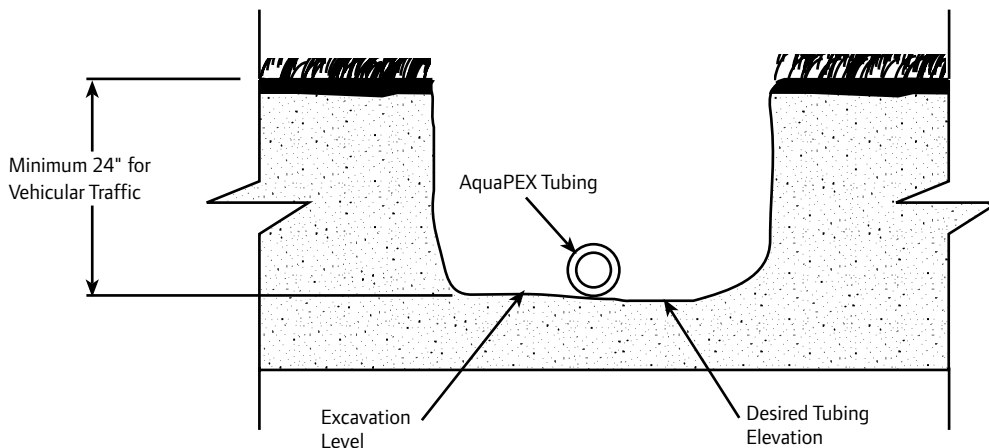

Figure 4-1: Trench Example of Good Surrounding Soil

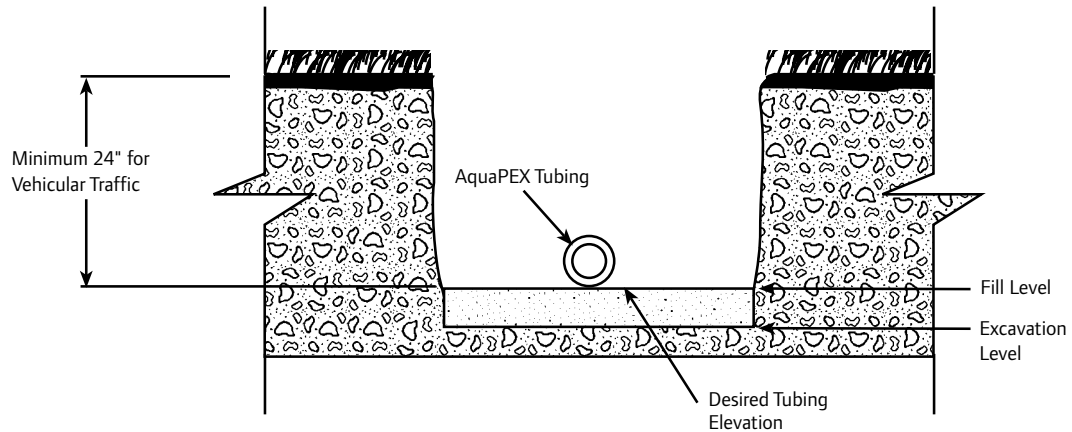

Figure 4-2: Trench Example of Bad Surrounding Soil

Bad Soil Conditions

If installing in rocky, clay, muddy or other poor soil conditions, it may be necessary to prepare the trench bottom using granular material of such size and grading to provide a stable base. See your local code for additional requirements.

Installation

Install Uponor AquaPEX tubing underground in a manner that avoids damage caused by external loads. External loads should not cause a decrease in the vertical dimension of the tubing cross-section more than 5% of the outside diameter. To ensure proper underground installation:

- Install Uponor AquaPEX tubing in a snaking pattern with sufficient slack in the line to allow for contraction of the line due to temperature change prior to backfilling.
- The linear expansion rate for Uponor AquaPEX tubing is approximately 1.1" per 10°F (5.6°C) temperature change for every 100' of tubing.
- Do not use blocking to support the tubing or change the tubing grade.
- Do not install potable water service tubing in, under or above cesspools, septic tanks, septic tank drainage fields or pits.

Joining Methods and Fittings

Use ProPEX or approved compression fittings to connect tubing to itself or to the corporation and curb stops. Check with Uponor or the fitting manufacturer for application suitability and proper usage instructions. Common fittings for direct burial include:

- Dezincification-resistant (DZR) Brass Fittings
- Red Brass Fittings
- Lead-free Brass Fittings
- EP Fittings
- Stainless Steel

You can identify the fitting type by the print stream on the fitting (e.g., c314 = Red Brass).

ProPEX Red Brass Adapters are a brass transition-fitting solution that is resistant to both dezincification and stress corrosion cracking due to its lower zinc content.

Note: Water service fittings designed for SDR-9 tubing available from other manufacturers (FordPack, AY McDonald and WIPEX™) are approved for use with Uponor AquaPEX tubing in cold-water service applications. A pipe stiffener for the appropriate size of PEX tubing is required for use with these fittings. Please contact the fitting manufacturer for temperature and pressure ratings.

Tubing Embedment

Proper soil selection, placement and compaction are essential in the area around the tubing. Use sand or gravel with a maximum particle size of $\frac{3}{4}$ " to backfill the tubing.

Compact the initial backfill around the tubing to provide adequate tubing support and prevent settlement. It is particularly important to compact the soil adequately around the tap connection. Uponor recommends that you pressurize the tubing prior to backfilling to reveal any damage. In heavy traffic areas, compact the backfill to 90% of maximum soil density.

Do not use highly plastic clays, silts, sharp or large rocks and organic materials as backfill in the immediate vicinity of the tubing. Compact the backfill from the sub-grade to a level compliant with local code that will cover the tubing 4" to 6". This will provide protection around the tubing and prevent settlement that puts stress on the fittings and the tubing.

For additional information about proper embedment practices, refer to ASTM D2774, Standard Recommended Practice for Underground Installation of Thermoplastic Pressure Piping, or AWWA Report TR31, Underground Installation of Polyolefin Piping.

Water System Disinfection

Disinfect Uponor AquaPEX tubing in accordance with AWWA C651, Standard for Disinfecting Water Mains, or in accordance with local codes.

Section 5: Ground and Top-out Stage of Installation

After installing the service water line into the building, the next area of focus is the groundwork — under and in the soon-to-be-poured concrete. The level of activity during the groundwork stage varies throughout the country. Areas doing primarily slab-on-grade construction may put the bulk of the tubing in the slab, below the slab or run it overhead in the attic. Traditional homes with basements will run the majority of tubing within the building framework.

Parts Inspection

To eliminate work delays, make sure all required material is at the job site prior to beginning a project. Use contractors trained to evaluate component suitability for installation. Check for material defects, incomplete parts or shipping damage. Check to see that the correct amount and type of PEX tubing is on site to start the project.

Installing Uponor AquaPEX Tubing During Ground Work

Pre-sleeved Uponor AquaPEX tubing is available for below-slab or in-slab installations to help protect the tubing from damage, to minimize permeation concerns and to protect the pipe from UV exposure prior to burial.

- Properly secure tubing at intervals necessary to keep the tubing from floating up during the pour.
- Best practices recommend using continuous lengths of tubing in or under the slab. If connections are necessary in the slab, use only EP fittings. For under-slab applications, the installer can use EP, Red Brass, Lead Free or DZR Brass ProPEX fittings.
- When bending, entering or exiting the slab, Uponor recommends using 90-degree bend supports or PVC elbows and sleeves to reduce the possibility of kinking the tubing during the pour or subsequent construction. Additionally, using supports will ensure proper tubing placement when exiting the slab.
- Maintain pressure on tubing installed in slab during the pour to facilitate leak detection.
- To protect against damage, sleeve the tubing if you anticipate sunlight exposure for more than 30 days.
- At the entry and exit points of the slab, cover the end of the tubing with a suitable black poly sleeve to prevent dirt and debris from entering the system.

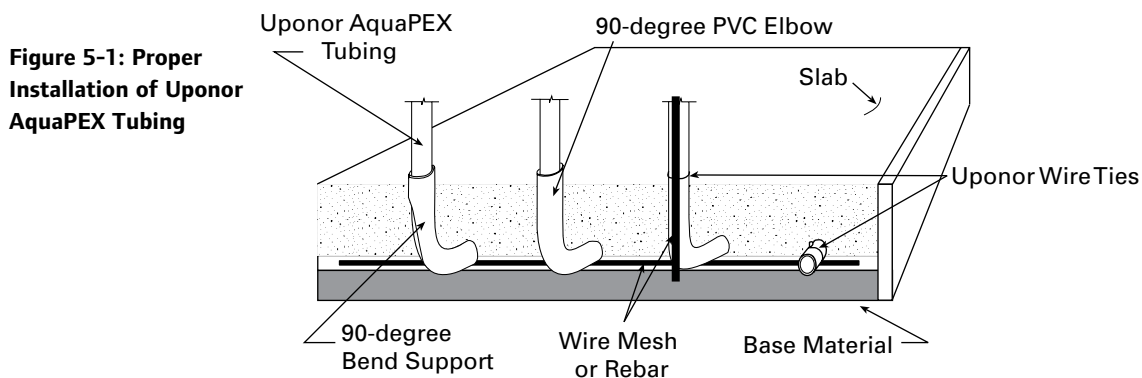

- If the tubing runs through an expansion joint, protect with a sleeve or dip below the joint. See **Figures 5-2 and 5-3**.

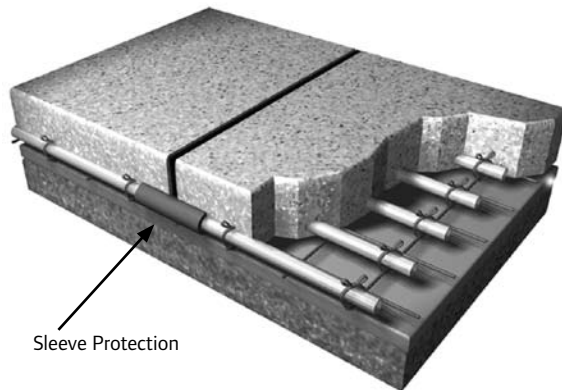

Figure 5-2: Sleeve Protection

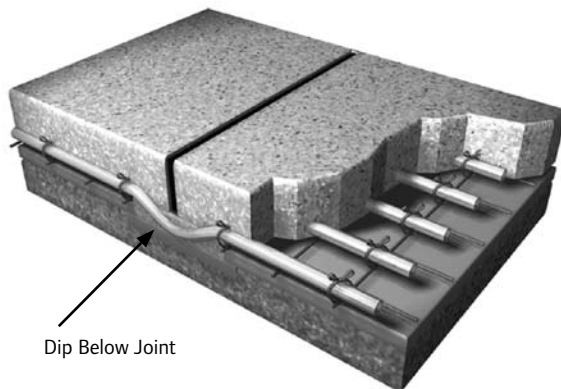

Figure 5-3: Dip Below Joint



Caution: Uponor recommends using a ProPEX EP coupling to repair tubing damaged during a concrete pour. If a ProPEX EP coupling is not available, you can use a ProPEX brass coupling wrapped with a protective polyethylene sleeve to prevent direct contact between the concrete and the brass coupling.

Termiticide or Pesticide Treatment

Uponor PEX tubing for hot- and cold-water distribution (plumbing) is approved for installation directly within or below concrete slabs where soil termiticide or pesticide treatment is required. This is especially useful in slab-on-grade construction. You are not required to sleeve PEX tubing installed within or below concrete slabs. We recommend using either flexible polyethylene (PE) protection sleeve or rigid polyvinyl chloride (PVC) bend guides at all slab penetrations to protect PEX tubing from abrasion where they pass through the concrete slab. These products are slab-penetration protection devices that you can use to fortify and protect the tubing.

When using Pre-sleeved Uponor AquaPEX tubing or a protection sleeve, an annular gap between these protection devices and the PEX tubing will exist. In such installations, you will need to fill the annular gap between the protection device and the PEX tubing at the exposed ends. This will help prevent pathways for pests or accidental application of harmful chemicals into the space between the PEX tubing and the protection device. Use only sealants that are compatible with PEX tubing.

Note: The following types of sealants are compatible for external contact on PEX tubing when sealing between PEX tubing and slab penetration protection devices:

- Latex Caulk
- Latex Foam
- Silicone Sealant
- Polyurethane Expanding Foam



Caution: The misapplication of termiticides or pesticides between PEX tubing and slab penetration protection devices could result in pooling or puddling of the products around the tubing, a prohibited practice. The application of pesticides or termiticides between PEX tubing and slab penetration protection devices is strictly prohibited.

1. If termiticides or pesticides are applied while the installed PEX tubing has exposed open ends not yet connected to plumbing fixtures, the ends of the tubing must be capped, plugged or closed to prevent these chemicals from entering the tubing.
2. Do not allow organic (petroleum-based) chemicals, petroleum distillates, termiticides or pesticides to come into direct contact with PEX tubing.
3. The annular gap between PEX tubing and slab-penetration protection devices (sleeving or PVC bend guides) at the ends of the tubing must be filled to help prevent pathways for pests and the mistaken

application of harmful chemicals into the space between the PEX tubing and the protection device. Use only sealants that are compatible with PEX tubing.

- When PEX tubing is continuously sleeved below or above a slab (e.g., when using ½" Pre-sleeved Uponor AquaPEX tubing), the space between the tubing and the sleeving must never be filled with any liquid chemical, including pesticides or termiticides. Prevent pooling or puddling of these liquids around PEX tubing.
- When it is necessary to retreat soil near PEX tubing, prevent the puddling or pooling of the termiticide or pesticide.

Installing Uponor AquaPEX Tubing in Frame Construction

Tubing Runs

- Leave extra tubing at the beginning and end of runs to simplify the connection to fittings, multi-ports and manifolds.
- Ensure runs are as direct as possible between fittings, multi-ports or manifolds and the fixtures they supply.
- Insulate hot- and cold- water tubing runs where code requires or as necessary.
- For information about locations and techniques for drilling through load-bearing construction, consult your local building codes.
- In residential or non-return plenum applications, you may bundle cold water tubing runs together and/or hot water tubing runs together with a suitable plastic material, unless prohibited by local code. Best practices do not recommend the bundling of hot-water tubing runs and cold-water tubing runs together.



Caution: When installing in attics, install the tubing below the insulation. Note the location of fittings in the attic space for inspection purposes during pressure testing.

Recessed Lighting

When installing Uponor AquaPEX tubing near recessed light fixtures, we recommend that the tubing be a minimum of 12" away from the light fixture. When it is necessary to install closer than 12" away from a light fixture, follow these guidelines:

- If there is not enough room in the joist cavity to meet the 12" restriction stated by Uponor, then insulation around the tubing is required.
- Use only insulation rated to withstand the temperature generated by the fixture.

- Insulate all tubing that is within 12" of the recessed light with closed-cell polyethylene, polyolefin or other suitable pipe insulation for a distance of 12" on either side of the light fixture.
- Insulation is required anytime a UV light source is used (including fluorescent bulbs); you must protect tubing from direct and indirect UV exposure.

Note: There are two types of recessed lights: Type I.C. (Insulated Ceiling), which allows direct contact with thermal insulation, and Type Non-I.C. (Non-insulated Ceiling), that requires a 3" minimal clearance from thermal insulation.

Tubing Supports: General Guidelines

- Uponor recommends using plastic or metal tubing supports designed for use with plastic tubing.
- Do not use supports that will damage the tubing. Inspect metal supports for sharp edges.
- Allow for the linear expansion rate of Uponor AquaPEX tubing — approximately 1.1" (27.9mm) per 10°F (5.6°C) temperature change for every 100' of tubing.
 - When installing tubing runs, thermal expansion calls for an extra ⅛" to ⅜" of longitudinal clearance per foot of run. Do not allow tubing to dip excessively between supports. Do not pull tubing tight during installation.
 - Do not rigidly anchor Uponor AquaPEX tubing with supports to allow tubing to expand and contract.
- Allow adequate clearance between PEX tubing and the structure (bored holes or sleeves) to allow tubing to move freely due to thermal expansion and contraction.

Tubing Supports: Horizontal Runs

- Along horizontal runs, install supports every 32". If horizontal runs are continuously supported (truss-to-truss), install a tube talon every second or third truss. Follow local code requirements when installing PEX tubing in fire-resistive construction floors, ceilings, or walls.

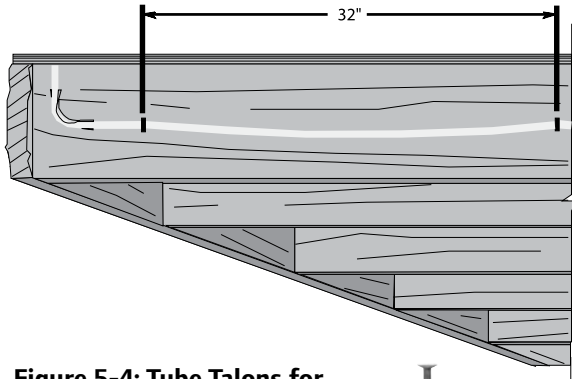

Figure 5-4: Tube Talons for Horizontal Runs



Tubing Supports: Vertical Runs

- Along vertical runs, install supports at the base of each floor and mid-story guide.

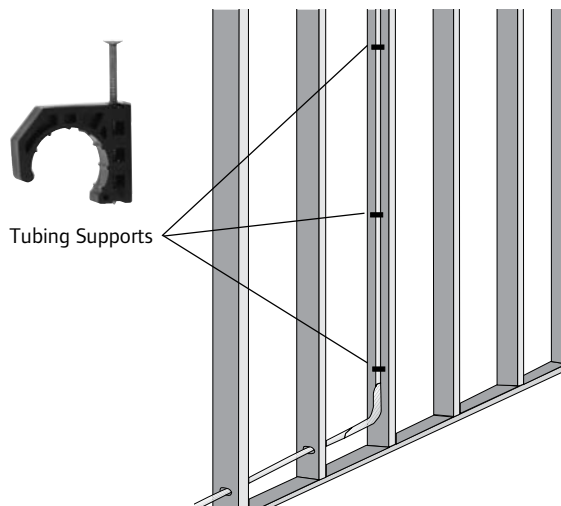

Figure 5-5: Tube Talon Supports for Vertical Runs

- Bends within 6" of a ProPEX connection require a tube talon or bend support (for 3/8" and 1/2" Uponor AquaPEX tubing).

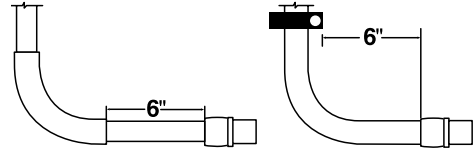

Figure 5-6: Tube Talon or Bend Support

- For 3/4" and 1" tubing, support is required for bends within 10" of a ProPEX connection.



Figure 5-7: Metal Bend Support

Multi-port Tee, Multi-port Elbow and Manifold Placement

Uponor offers a variety of engineered plastic (EP) multi-port tees and elbows designed for demanding slab-on-grade plumbing applications that eliminate the need for multiple connections.

- Uponor EP components are immune to the normal corrosion, pitting and scaling usually associated with copper and brass components.
- For detailed information on manifold placement and connections, refer to the Engineered Plastic (EP) Valved Manifolds Installation Guide.

Common Components

Bend Supports

- Use Uponor bend supports to hold the tubing in a 90-degree bend. It is common to use bend supports when exiting a slab to control the direction of the tubing out of the slab.
- Snap-on bend supports are available in metal and plastic for 3/8", 1/2" and 3/4" PEX.
- PVC conduit supports are available for 3/8" to 1" PEX tubing as an alternative to the snap-on bend supports.



Figure 5-8: Support for 90-degree Bend

Drop Ear Bend Supports

- Drop Ear Bend Supports provide a rigid, connection-free, 90-degree exit from a standard 2" x 4" (or larger) stud wall or floor.
- Nail the flange to the front edge of the stud for support. A horizontal brace is required to position the Drop Ear Bend Support between two studs.
- Drop Ear Bend Supports are available in metal and plastic for $\frac{3}{8}$ " and $\frac{1}{2}$ " PEX.



Figure 5-9: Drop Ear Supports

ProPEX Out-of-the-Wall Support System

The ProPEX Out of the Wall Support System is a complete, easily installed system that makes exiting the wall with PEX easier than ever. This system includes:

- PEX Wall Support Bracket with alternating $\frac{1}{2}$ " and $\frac{3}{4}$ " holes
- $\frac{1}{2}$ " Plastic Bend Support

- ProPEX Escutcheon in chrome or white finish for $\frac{1}{2}$ " PEX tubing
- The plastic bend support snaps into the mating wall support bracket, providing rigid support from all angles.
- The escutcheon allows you to make a ProPEX connection inside the sleeve and fully concealed.

Installation Example (See Figure 5-10)

1. Feed the Uponor AquaPEX tubing through the wall opening.
2. Measure 2" to 2 $\frac{3}{16}$ " from the wall and mark the tubing. **Note:** If you cut the tubing at 2 $\frac{3}{16}$ ", this will allow enough length for additional adjustments, but may require re-cutting.
3. Square-cut the tubing after measuring for the desired cut location.
4. Slide the ProPEX Escutcheon towards exposed tubing. Then slide the flared sleeve over the exposed tubing and position the escutcheon against the wall.
5. Slide on the ProPEX Ring until it hits the stop edge.
6. Ensure that you have properly aligned all components. If necessary, remove the escutcheon and sleeve; then re-cut the tubing to the appropriate length.
7. Expand the ProPEX Ring and tubing according to instructions.
8. Fully insert the stop valve into the expanded tubing until the ring hits the stop of the valve.

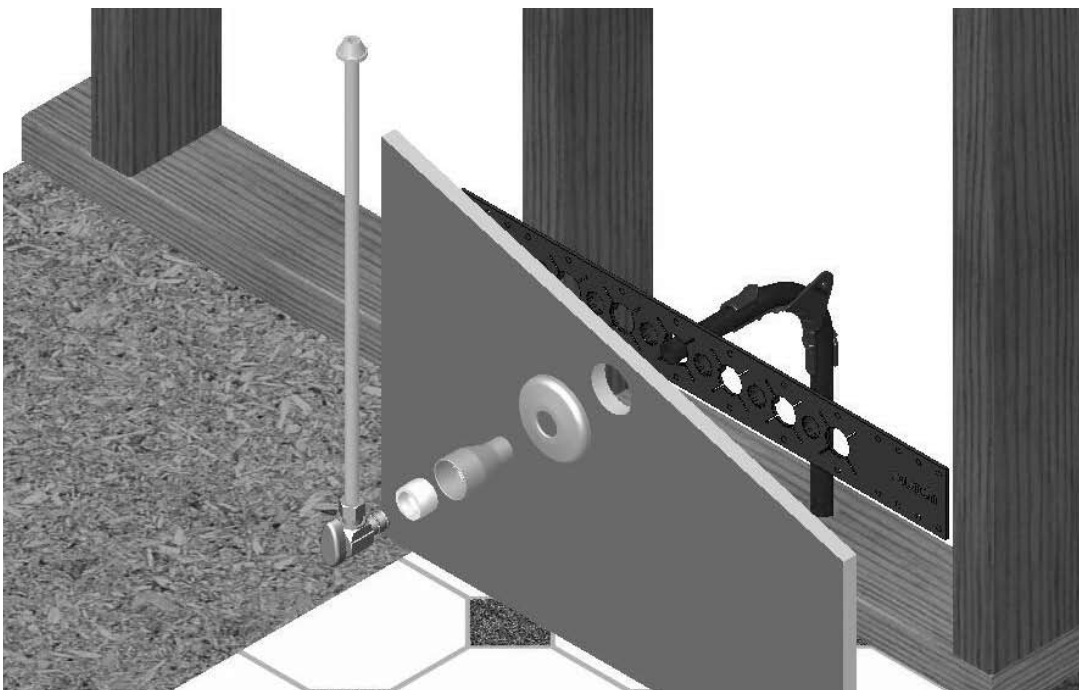

Figure 5-10: Installation Example of ProPEX Out-of-the-Wall Support System



Drop Ear Elbows

The ProPEX Drop Ear Brass Elbow provides a rigid 90-degree bend and the ability to secure $\frac{3}{8}$ " or $\frac{1}{2}$ " Uponor AquaPEX tubing where it exits a stud wall or connects to a showerhead.

Figure 5-11: Drop Ear Elbow for Rigid Bend

Metal Straight-through Supports

Uponor Straight-through Supports provide rigid support and the ability to secure Uponor AquaPEX tubing as it exits a wood floor.

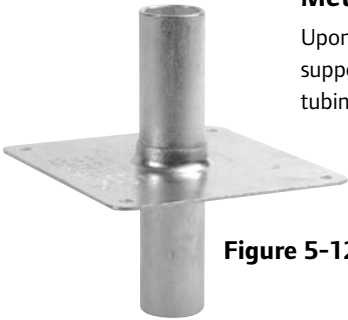

Figure 5-12: Straight-through Support

Steel-plate Protectors

The Steel Plate Protector (F5700002) protects installed tubing from possible damage (e.g., if tubing is in danger of damage by drywall, paneling, trim screws or nails).

- Use these protectors to safeguard your installation during and after construction.
- If Uponor AquaPEX tubing passes through hollow masonry walls or metal studs, always protect with suitable sleeves or grommets.

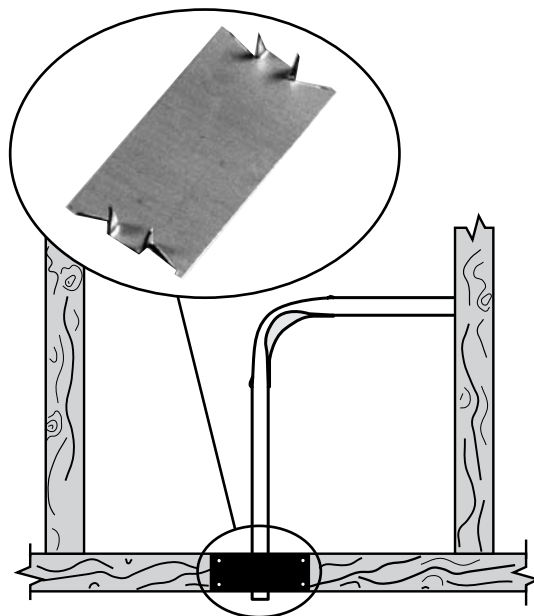

Figure 5-13: Steel-plate Protectors

Water Hammer Arrestors

Uponor AquaPEX tubing withstands repeated pressure surges well beyond its rated pressure capacity.

- Uponor AquaPEX tubing minimizes surge pressure (65% less than stiff pipes).
- Water hammer arrestors are only necessary if local code requires them.

Shower Valve Connections

Uponor AquaPEX tubing is suitable for hot and cold inlets on the shower valve, as well as the supply to the showerhead. Refer to Figure 5-14 for an illustration of valve connections.

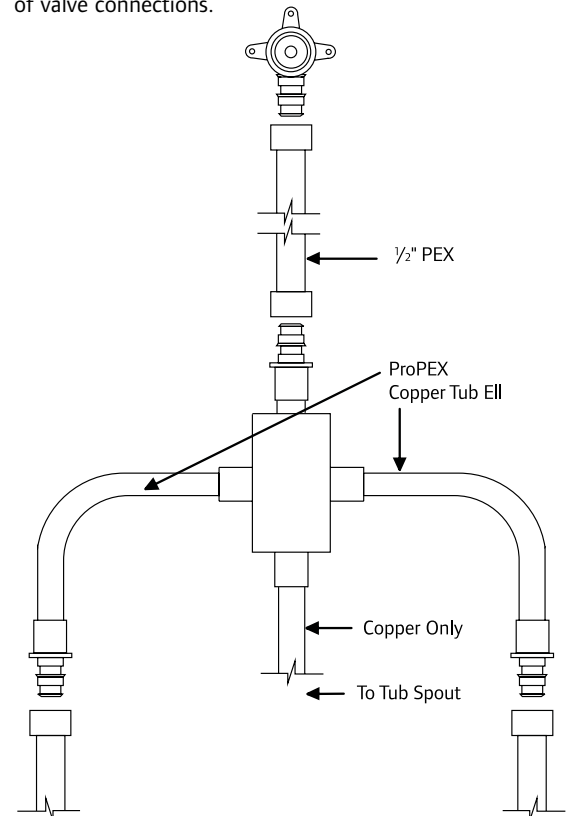

Figure 5-14: Valve Connection Example

ProPEX Copper Tub Ells

The ProPEX Copper Tub Ell provides a 90-degree transition from tub and shower valve to Uponor AquaPEX tubing.

- Uponor offers this product in several sizes. Refer to the Uponor Product Catalog for a complete listing.

Caution: Do not use Uponor AquaPEX tubing to connect the tub and shower valve to the tub downspout as this may create excessive backpressure in the valve, causing it to remain slightly open.



Figure 5-15: Tub Ell

ProPEX Copper Stub Ells

Uponor Copper Stub Ell provides a 90-degree transition from Uponor AquaPEX tubing to copper.

- Uponor offers this product in several sizes. Refer to the Uponor Product Catalog for a complete listing.
- You may use a ProPEX Copper Stub Ell at the fixture to exit from the wall instead of a Drop Ear Bend Support.



Figure 5-16: Stub Ell

Hose Bibs

- Connect Uponor AquaPEX tubing to a standard hose bib using a ProPEX threaded or sweat adapter.
- Rigidly anchor the hose bib to prevent it from loosening.

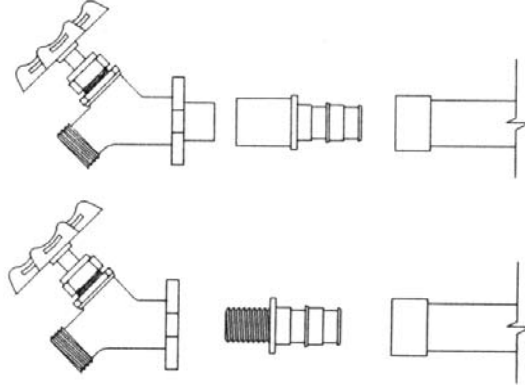

Figure 5-17: Standard Hose Bibs

Pressure Test the System

- You must pressure test the system in accordance with local code requirements, but the recommended test pressure is at least 25 psi above working pressure or 100 psi. Slight fluctuations of pressure are normal due to ambient temperature changes.
- When testing with air, let the system pressure stabilize before starting the test.
- Test pressures above 160 psi will cause a slight radial expansion of the tubing and a subsequent relaxation of the material, resulting in a reduction of test pressure. This is normal and does not indicate a leak.
- When using valved manifolds, open the valves on the manifold prior to pressure testing. Ensure the valves remain open until the pressure test is complete.

Back-draining the System

- If you anticipate that the structure will be unoccupied during cold climate, allow a drain for the system and blow out any remaining water with air.



Figure 5-18: Washing Machine Outlet Box

Washing Machine Outlet Box

- Use the Uponor Washing Machine Outlet Box (Q5930500) to transition Uponor AquaPEX tubing to washing machine valves.
- Connect Uponor AquaPEX tubing to the valves using a ½" ProPEX connection.



Figure 5-19: Ice Maker Outlet Box

Ice Maker Outlet Box

- Use the Uponor Ice Maker Outlet Box (Q5955025) or ProPEX In-line Ice Maker Tee (Q4455050) to supply the icemaker.
- Connect Uponor AquaPEX tubing using a ½" ProPEX connection.

Refer to the Uponor Product Catalog for optional icemaker fittings.



Caution: Ice Maker Saddle Valves are not suitable for use with PEX tubing. Uponor does not warrant their use on AquaPEX tubing.

Section 6:

Final Stage of Installation

During the final stage of installation, install the finishing items in the structure. Set and connect all lavs, tubs and water closets. This section discusses the supporting components used at this stage.

Straight and Angle Stop Valves

Point of use at the fixture is the intended use of ProPEX straight and angle stop valves. These valves allow for direct transition from PEX tubing to the riser. To review ProPEX connections, refer to Section 3. Uponor features the following types:

- EP Straight and Angle Stop Valves
- Chrome Plated Brass ProPEX Straight and Angle Stop Valves
- Chrome Plated Brass Compression Straight and Angle Stop Valves

EP Valves

EP Straight and Angle Stop Valves are constructed of durable engineered plastic and precision-cut ceramics. They resist chemical and mineral build-up, along with corrosion, pitting and scaling and they enable PEX-to-PEX and point-of-use shutoff at the fixture.



Figure 6-1: EP Angle and Straight Valves

Chrome Plated Brass Compression Stop Valves (Straight and Angle)

Because Uponor AquaPEX tubing has the same outside diameter as standard copper pipe, you can use standard compression straight and angle stop valves with Uponor AquaPEX tubing. An insert stiffener is required. The insert is included with the stop valves from Uponor. You can also purchase inserts separately when needed.



Figure 6-2: Brass Compression Stop Valves

Directions for Use

1. Square-cut the tubing perpendicular to the tubing length.
 2. Place the nut and then the compression ring over the end of the tubing.
 3. Use the brass compression ring included with the stop valve.
 4. Install the brass or stainless steel insert into the tubing end. Be sure to set the insert completely against the end of the tubing.
 5. Slowly tighten the compression nut to the opposing thread.
- Note:** Re-tighten all compression fittings after initial installation.
6. Wait 30 minutes to allow the tubing to relax, and then re-tighten each fitting.



Figure 6-3: Uponor AquaPEX Risers

Uponor AquaPEX Risers

Install Uponor AquaPEX $\frac{3}{8}$ " outside diameter (OD) risers with Delrin-engineered plastic compression rings included with the risers. The risers are available in the following sizes:

- 12" Lav
- 20" Lav
- 30" Lav
- 36" Lav
- 12" Closet
- 20" Closet

Lav Risers

- Uponor AquaPEX Lav Risers are sold with a Delrin-engineered plastic compression ring. You can also purchase metal washers (sold separately).
- The metal washer assures that the riser is compatible with compression nuts of various opening sizes.
- If the Delrin-engineered plastic compression ring is used, do not use an insert. You will need a $\frac{1}{4}$ " insert if a metal ring is substituted.
- Uponor AquaPEX Lav Risers are listed to NSF 14 and 61.

Note: Uponor recommends using $\frac{1}{4}$ " Uponor AquaPEX Riser Washers in hot-water applications.

Closet Risers

- Closet risers are compatible with off-the-shelf compression nuts.
- Closet risers are sold with a Delrin-engineered plastic compression ring.
- Closet risers are not sold with the metal washer. Do not use the metal washer to connect to closets.
- If a Delrin-engineered plastic compression ring is used, do not use an insert. If substituting a metal ring, a $\frac{1}{4}$ " insert is required.

Note: Do not heat Uponor AquaPEX Risers to remove kinks. Do not install kinked or damaged risers.

See the Uponor Product Catalog for the various styles, part numbers and descriptions of all available Uponor plumbing products.

Section 7:

Plumbing Inspector Checklist

This checklist serves as a guideline to the local authority and may not include all applicable requirements. Please review guidelines for the codes and standards in **Section 1** of this installation guide as well as the local code in your area for additional guidelines and restrictions.

Note: If any conflict exists between the information contained in this installation guide and that of the local code, the local code always takes precedence.

Tubing, Fittings and Valves

- Uponor AquaPEX tubing — ASTM F876, ASTM F877, CSA B137.5, NSF-pw
- ProPEX fittings — Manufactured and listed to ASTM F1960 and CSA B137.5
- Valves – ASME A112.18.1 or CSA B125.3, NSF 61

Uponor offers a full line of EP products, including the EP Valveless and EP Flow-through Valveless manifolds; the EP Branch and EP Flow-through Multi-port tees; and various elbows, couplings, end caps, plugs and faucet adapters.

The Uponor ProPEX connection method is compatible with all Uponor EP products. For detailed information on manifold placement and connections, refer to the Engineered Plastic (EP) Valved Manifolds Installation Guide.

Tubing Limitations

- Do not expose Uponor AquaPEX tubing to direct sunlight for more than 30 days.
- Do not install Uponor AquaPEX tubing within 6" of any gas appliance vents, with the exception of double-wall B-vents or plastic vents (with a minimum clearance of 1").
- Do not install Uponor AquaPEX tubing within 12" of recessed light fixtures, unless you have protected the PEX line with suitable insulation.

Joints and Connections

- Square-cut all tubing ends and ensure they are free of burrs and debris before making a connection.
- Ensure fittings and connections comply with manufacturer recommendations.
- Make transition joints with manufacturer-approved fittings.

ProPEX Fittings

- Seat the Uponor AquaPEX tubing and ProPEX Ring fully against the shoulder of the fitting. The maximum gap should be no more than the thickness of a credit card.
- To correct an improper connection, cut a minimum of 2" from the end of the tubing and use a new ProPEX Ring.

Tubing Supports

- Use plastic or metal supports designed for use with plastic tubing.
- Place horizontal support every 32" for PEX tubing. If installed in fire-rated construction, local code requirements are in force.
- Provide vertical support every 4 to 5 feet with a mid-story guide placed between floors.
- Bends within 6" of a ProPEX connection to $\frac{3}{8}$ " and $\frac{1}{2}$ " tubing and within 10" of a ProPEX connection to $\frac{3}{4}$ " and 1" tubing require support.
- Allow $\frac{1}{8}$ " to $\frac{3}{16}$ " of slack per foot of run on installed Uponor AquaPEX tubing for expansion and contraction.

General Recommendations

- Protect Uponor AquaPEX tubing passing through hollow masonry walls or metal studs with sleeves or grommets. Protective sleeves or grommets are not required when AquaPEX passes through wood studs or joists.
- Protect Uponor AquaPEX tubing from damage (e.g., nail, screw, etc.) with Steel Plate Protectors (F5700002).
- The minimum bend radius of PEX is six times the outside diameter.
- Uponor EP, DZR, Red Brass or Lead-free fittings are suitable for burial.

Pressure Testing

- During the rough-in stage, open all valves prior to pressure testing. These valves are to remain open until the pressure test is complete.
- You must pressure test the system to the system working pressure (40 to 60 psi) with air or water. Consult the local code and pressure test at the current ambient temperature. Slight fluctuations of pressure are normal due to ambient temperature changes.



Caution: If using water to pressure test the system, purge all water from the system prior to ambient air temperatures nearing 32°F (0°C). Failing to remove the water from the system can result in damage to the tubing and associated equipment.

Uponor, Inc.
5925 148th Street West
Apple Valley, MN 55124 USA
Tel: 800.321.4739
Fax: 952.891.2008
Web: www.uponor-usa.com

Uponor Ltd.
2000 Argentia Rd., Plaza 1, Ste. 200
Mississauga, ON L5N 1W1 CANADA
Tel: 888.994.7726
Fax: 800.638.9517
Web: www.uponor.ca

Uponor