

VIC®-300 MasterSeal™ Butterfly Valves

SERIES 761

Vic®-300 MasterSeal™ butterfly valves are designed for pressures ranging from full vacuum to 300psi/2065kPa and for bi-directional, dead end services to full working pressure. The valve features a patented seat design that assures full 360° sealing. The pressure-enhanced seat compresses to form a larger seating area as the pressure increases. The seat design also contributes to the low breakaway torque capabilities of the MasterSeal valve. Valve construction and performance meet or exceed MSS-SP-67 requirements.

Available in 2 – 12”/50 – 300 mm sizes the valve is offered with a standard ISO mounting flange to accept most gear and power actuators. Vic-300 MasterSeal butterfly valves 2 – 6”/50 – 150 mm are offered with a 10-position handle that may be configured for infinitely variable service with memory lock stop and is pad-lockable. Sizes 8”/200 mm valves are available with a lever lock handle that may be configured for infinitely variable service with memory stop and is padlockable. 2 – 12”/50 – 300 mm sizes are available with a gear operator and can easily be configured into three way assemblies. Vic-300 Masterseal butterfly valves accommodate 2”/50 mm of insulation. An additional 2”/50 mm neck extension is available when more than 2”/50 mm of insulation is needed. A 4½”/120 mm long hand wheel input shaft extension is available for valve sizes 2 – 8”/50 – 200 mm and a 3½”/90 mm long hand wheel input shaft extension is available for 10 – 12”/25 – 300 mm valve sizes. **Note: Hand Wheel Input Shaft Extensions are not for use with Chain Wheels.**

Available seats include EPDM for water services to +250°F/+121°C. Vic-300 MasterSeal valves are also offered with permanently lubricated Nitrile material that is recommended for oil, air, and gas services. For specific material specifications on varied services please request publication 05.01. For dry gas service, Victaulic recommends the lubricated nitrile option. Valves with standard disc and EPDM seat are UL classified to ANSI/NSF 61. Victaulic also offers a tamper resistant option for 2 – 8”/50 – 200 mm size Vic-300 MasterSeal butterfly valves.

NOTES:

A padlockable valve refers to those valves which can be padlocked to lockout equipment for preventing inadvertent valve operation. When used in conjunction with an appropriate lockout/tagout systems, multiple padlocks may be used. The valve may be padlocked either fully open or fully closed.

A tamper resistant option is meant to deter theft, vandalism or other malicious activity. The handles and associated components are assembled with tamper resistant fasteners which are designed for one time assembly. Attempts to defeat the padlock by partial disassembly of the valve will likely result in evidence of such activity. The valve may be padlocked either fully open or fully closed.



FEATURES

- 1 **Disc** – Electroless nickel coated ductile iron.
Optional:
 - Aluminum Bronze
 - Stainless Steel
- 2 **Seat** – Patented pressure enhanced rubber seat design
- 3 **Drive Hub** – Designed to accept nearly all types of actuation
- 4 **Stem Seals** – Prevents leakage of media.
- 5 **Upper and Lower Stem Bearings** – Helps maintain constant low torque values for the life of the valve.
- 6 **Stem** – Blow out proof design utilizing stainless steel.
- 7 **ISO 5211 Mounting Flange** – Accepts ISO standard actuators
 - 2 - 8”/50 – 200 mm are flange size F07
 - 10 - 12”/250 – 300 mm are flange size F10
- 8 **Grooved End Body** – Reduces the weight of the valve and makes it easier to install.
- 9 **Rectangular Drive** – Positive rectangular drive eliminates fasteners in the flow stream. Design prevents replacement errors.
- 10 **Seal Cartridge** – Patented seal cartridge houses stem seals.
- 11 **Thermal Barrier** – Reduces condensation on gear operators when installed in chilled water applications.

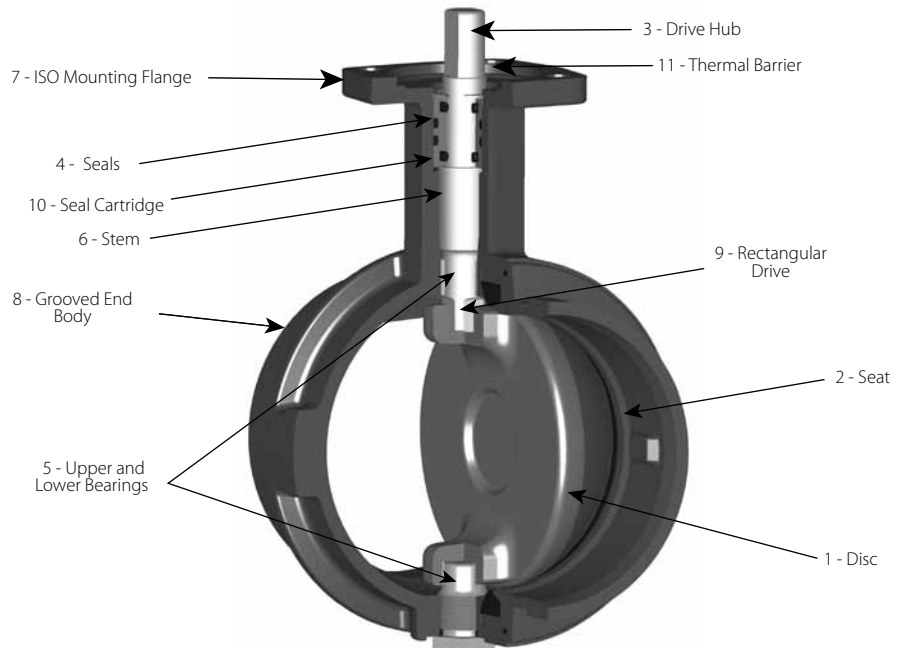

JOB/OWNER

System No. _____
Location _____

CONTRACTOR

Submitted By _____
Date _____

ENGINEER

Spec Sect _____ Para _____
Approved _____
Date _____

VIC[®]-300 MasterSeal[™] Butterfly Valves

SERIES 761

MATERIAL SPECIFICATIONS

Body: Ductile iron conforming to ASTM A-536, grade 65-45-12

End Face, 2 – 6"/50 – 150 mm: Ductile iron conforming to ASTM A-536, grade 65-45-12

Seal Retainer, 8 – 12"/200 – 300 mm: Ductile iron conforming to ASTM A-536, grade 65-45-12

Coating: Black alkyd enamel

Disc: Ductile iron (standard) conforming to ASTM A-536, grade 65-45-12, with electroless nickel coating conforming to ASTM B-733

Optional:

- Aluminum bronze, Grade C95500, available 2-6" only
- Stainless steel conforming to ASTM A-351, Grade CF8M, available 2-12"

Seat: (specify choice)*

• **Grade "E" EPDM**

EPDM (Green color code). Temperature range –30°F to +250°F/–34°C to +121°C.

Recommended for cold and hot water service within the specified temperature range plus a variety of dilute acids, and many chemical services. UL Classified in accordance with ANSI/NSF 61 for cold +86°F/+30°C potable water services. NOT RECOMMENDED FOR PETROLEUM SERVICES.

• **Grade "T" Lubricated Nitrile**

Nitrile (Orange color code). Temperature range –20°F to +180°F/–29°C to +82°C.

Recommended for petroleum products, air with oil vapors, oil-free gas, vegetable and mineral oils within the specified temperature range. NOT RECOMMENDED FOR HOT WATER SERVICES OVER +150°F/+66°C OR FOR HOT DRY AIR OVER +140°F/+60°C.

• **Grade "O" Fluoroelastomer**

Fluoroelastomer (Blue color code). Temperature range +20°F to +300°F/–7°C to +149°C.

Recommended for many oxidizing acids, petroleum oils, halogenated hydrocarbons, lubricants, hydraulic fluids, organic liquids. NOT RECOMMENDED FOR HOT WATER SERVICES.

* Services listed are General Service Recommendations only. It should be noted that there are services for which these seals are not recommended. Reference should always be made to the latest Victaulic Gasket Selection Guide for specific service recommendations and for a listing of services which are not recommended.

VIC®-300 MasterSeal™ Butterfly Valves

SERIES 761

MATERIAL SPECIFICATIONS

Stems: (Standard) 416 stainless steel conforming to ASTM A-582

- **Optional*:** 17-4PH stainless steel conforming to ASTM A-564

Stem Seal Cartridge: (Standard) C36000 brass

- **Optional*:** 17-4PH stainless steel conforming to ASTM A-564

Bearings: Fiberglass or 316 stainless steel with TFE lining

Stem Seals: Furnished in same materials as seat

Stem Retaining Ring: Carbon steel

Handle: Lever Lock

- For sizes 8"/200mm - Painted ductile iron conforming to ASTM A-536, grade 65-45-12, with carbon steel latch plate and carbon steel zinc plated fasteners
 - For sizes 8"/200mm - Infinitely variable, padlockable and includes memory stop. Optionally available with tamper-resistant hardware.
- For sizes 10 – 12"/250 – 300mm - Painted ductile iron conforming to ASTM A-536, grade 65-45-12, with carbon steel handle extension and carbon steel zinc plated fasteners.

Handle: 10 Position

- For sizes 2 – 6"/50 – 150mm - Zinc plated carbon steel handle with zinc plated carbon steel latch plate and carbon steel zinc plated fasteners, infinitely variable, padlockable and includes memory stop. Optionally available with tamper-resistant hardware.

Gear Operator with options below:

- Handwheel with memory stop
- Handwheel with chainwheel
- 2" square nut
- Thermal Barrier

* Contact Victaulic for available material combination options.

VIC[®]-300 MasterSeal[™] Butterfly Valves

SERIES 761

DIMENSIONS

Bare

Size		Dimensions – Inches/millimeters																Approx. Wgt. Ea.		
Nominal Size In./mm	Actual Outside Diameter In./mm	A End to End	B	C	D	E	F	G	H	J	K	L	M	N	P	Q-Key	Bare Valve Lbs./kg	Valve with Lever Handle Lbs./kg	Valve with 10-Position Handle Lbs./kg	
2	2.375	3.21	3.25	1.44	—	—	1.81	3.81	2.17	0.13	0.34	2.756	0.88	0.32	0.43	—	3.5	6.0	4.4	
50	60.3	81.5	82.6	36.6	—	—	46.0	96.8	55.2	3.3	8.6	70.0	22.4	8.0	11.0	—	1.6	2.7	2.0	
2½	2.875	3.77	4.00	1.77	—	—	2.10	4.25	2.17	0.13	0.34	2.756	0.88	0.32	0.43	—	5.0	7.5	5.9	
65	73.0	95.8	101.6	45.0	—	—	53.3	108.0	55.2	3.3	8.6	70.0	22.4	8.0	11.0	—	2.3	3.4	2.7	
76.1 mm	3.000	3.77	4.00	1.77	—	—	2.10	4.25	2.17	0.13	0.34	2.756	0.88	0.32	0.43	—	5.0	7.5	5.9	
	76.1	95.8	101.6	45.0	—	—	53.3	108.0	55.2	3.3	8.6	70.0	22.4	8.0	11.0	—	2.3	3.4	2.7	
3	3.500	3.77	4.50	1.77	—	—	2.35	4.50	2.17	0.13	0.34	2.756	0.88	0.32	0.43	—	6.0	8.5	6.9	
80	88.9	95.8	114.3	45.0	—	—	59.7	114.3	55.2	3.3	8.6	70.0	22.4	8.0	11.0	—	2.7	3.9	3.1	
108.0 mm †	4.250	4.63	5.50	2.20	—	—	2.88	5.25	2.17	0.13	0.34	2.756	0.89	0.43	0.59	—	9.3	11.8	10.8	
	108.0	117.6	139.7	55.8	—	—	73.2	133.4	55.2	3.3	8.6	70.0	22.6	11.0	15.0	—	4.2	5.4	4.9	
4	4.500	4.63	5.50	2.18	—	—	2.88	5.25	2.17	0.13	0.34	2.756	0.89	0.43	0.59	—	9.3	11.8	10.8	
100	114.3	117.6	139.7	55.4	—	—	73.2	133.4	55.2	3.3	8.6	70.0	22.6	11.0	15.0	—	4.2	5.4	4.9	
133.0 mm †	5.250	5.88	6.30	2.58	—	—	3.34	6.25	2.17	0.13	0.34	2.756	1.12	0.50	0.75	—	16.8	20.0	18.8	
	133.0	149.4	160.0	65.5	—	—	84.8	158.8	55.2	3.3	8.6	70.0	28.5	12.7	19.1	—	7.6	9.1	8.5	
139.7 mm	5.500	5.88	6.30	2.58	—	—	3.34	6.25	2.17	0.13	0.34	2.756	1.12	0.50	0.75	—	16.8	20.0	18.8	
	139.7	149.4	160.0	65.5	—	—	84.8	158.8	55.2	3.3	8.6	70.0	28.5	12.7	19.1	—	7.6	9.1	8.5	
5	5.563	5.88	6.30	2.58	—	—	3.34	6.25	2.17	0.13	0.34	2.756	1.12	0.50	0.75	—	16.8	20.0	18.8	
125	141.3	149.4	160.0	65.5	—	—	84.8	158.8	55.2	3.3	8.6	70.0	28.5	12.7	19.1	—	7.6	9.1	8.5	
159.0 mm †	6.250	5.88	7.30	2.58	0.42	—	3.83	6.75	2.17	0.13	0.34	2.756	1.12	0.50	0.75	—	20.0	23.2	22.0	
	159.0	149.4	185.4	65.5	10.6	—	97.3	171.5	55.2	3.3	8.6	70.0	28.5	12.7	19.1	—	9.1	10.5	10.0	
165.1 mm	6.500	5.88	7.30	2.58	0.42	—	3.83	6.75	2.17	0.13	0.34	2.756	1.12	0.50	0.75	—	20.0	23.2	22.0	
	165.1	149.4	185.4	65.5	10.6	—	97.3	171.5	55.2	3.3	8.6	70.0	28.5	12.7	19.1	—	9.1	10.5	10.0	
6	6.625	5.88	7.30	2.58	0.42	—	3.83	6.75	2.17	0.13	0.34	2.756	1.12	0.50	0.75	—	20.0	23.2	22.0	
150	168.3	149.4	185.4	65.5	10.6	—	97.3	171.5	55.2	3.3	8.6	70.0	28.5	12.7	19.1	—	9.1	10.5	10.0	
8	8.625	5.33	10.00	2.33	1.47	0.80	5.00	8.00	2.17	0.13	0.34	2.756	1.30	—	0.88	0.188 x .88 4.78 x 22.35	34.3	37.5	—	
200	219.1	135.4	254.0	59.2	37.4	20.3	127.0	203.2	55.2	3.3	8.6	70.0	33.0	—	22.2	—	15.6	17.0	—	
10	10.750	6.40	12.25	3.00	1.81	1.41	6.13	9.75	2.76	0.13	0.43	4.016	2.25	—	1.25	0.312 x 1.88 7.92 x 47.75	72.0	84.0	—	
250	273.0	162.6	311.2	76.2	45.9	35.8	155.7	247.7	70.1	3.3	11.0	102.0	57.2	—	31.8	—	32.7	38.1	—	
12	12.750	6.50	14.25	3.00	2.80	2.30	7.13	10.75	2.76	0.13	0.43	4.016	2.24	—	1.25	0.312 x 1.88 7.92 x 47.75	88.0	100.0	—	
300	323.9	165.1	362.0	76.2	71.0	58.4	181.1	273.1	70.1	3.3	11.0	102.0	56.9	—	31.8	—	39.9	45.4	—	

† Contact Victaulic for availability.

NOTE: 2 – 8"/50 – 200 mm sizes are ISO Flange Designation F07; 10 and 12"/250 and 300 mm sizes are ISO Flange Designation F10.

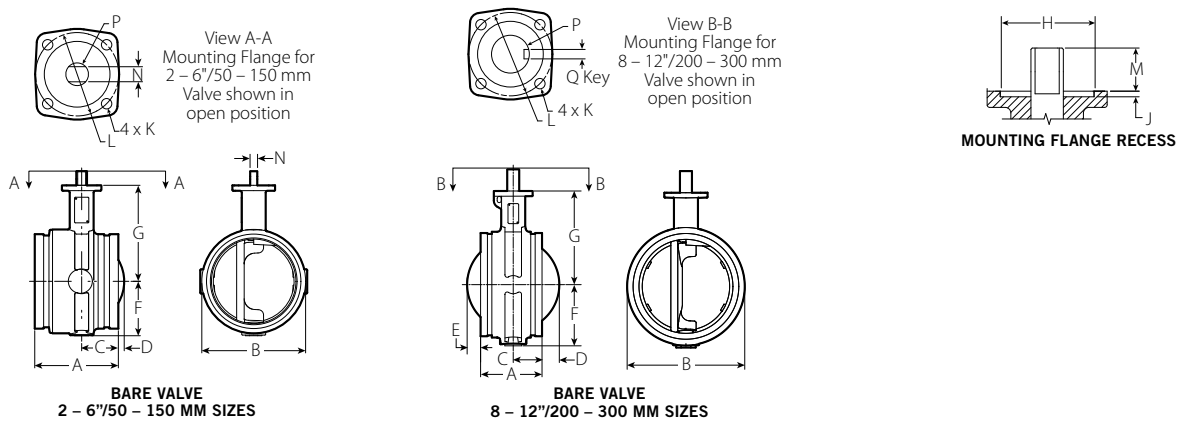

VIC®-300 MasterSeal™ Butterfly Valves

SERIES 761

DIMENSIONS

With Handle

Size		Dimensions – Inches/millimeters			Approx. Wgt. Ea.	
Nominal Size In./mm	Actual Outside Diameter In./mm	A End to End	T-R	U	Bare Valve Lbs./kg	Valve with Lever Handle Lbs./kg
2	2.375	3.21	7.00	1.57	3.5	6.0
50	60.3	81.5	177.8	39.9	1.6	2.7
2½	2.875	3.77	7.00	1.57	5.0	7.5
65	73.0	95.8	177.8	39.9	2.3	3.4
76.1 mm	3.000	3.77	7.00	1.57	5.0	7.5
	76.1	95.8	177.8	39.9	2.3	3.4
3	3.500	3.77	7.00	1.57	6.0	8.5
80	88.9	95.8	177.8	39.9	2.7	3.9
108.0 mm †	4.250	4.63	8.50	1.64	9.3	11.8
	108.0	117.6	215.9	41.7	4.2	5.4
4	4.500	4.63	8.50	1.64	9.3	11.8
100	114.3	117.6	215.9	41.7	4.2	5.4
133.0 mm †	5.250	5.88	12.00	1.64	16.8	20.0
	133.0	149.4	304.8	41.7	7.6	9.1
139.7 mm	5.500	5.88	12.00	1.64	16.8	20.0
	139.7	149.4	304.8	41.7	7.6	9.1
5	5.563	5.88	12.00	1.64	16.8	20.0
125	141.3	149.4	304.8	41.7	7.6	9.1
159.0 mm †	6.250	5.88	12.00	1.64	20.0	23.2
	159.0	149.4	304.8	41.7	9.1	10.5
165.1 mm	6.500	5.88	12.00	1.64	20.0	23.2
	165.1	149.4	304.8	41.7	9.1	10.5
6	6.625	5.88	12.00	1.64	20.0	23.2
150	168.3	149.4	304.8	41.7	9.1	10.5
8	8.625	5.33	14.00	1.51	34.3	37.5
200	219.1	135.4	355.6	38.4	15.6	17.0
10	10.750	6.40	11.66	4.50	72.0	84.0
250	273.0	162.6	296.2	114.30	32.7	38.1
12	12.750	6.50	11.66	4.50	88.0	100.0
300	323.9	165.1	296.2	114.3	39.9	45.4

† Contact Victaulic for availability.

NOTE: 2 – 8”/50 – 200 mm sizes are ISO Flange Designation F07; 10 and 12”/250 and 300 mm sizes are ISO Flange Designation F10.

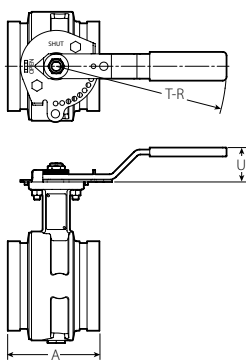

10-POSITION HANDLE WITH MEMORY STOP
2 – 6”/50 – 150 MM SIZES

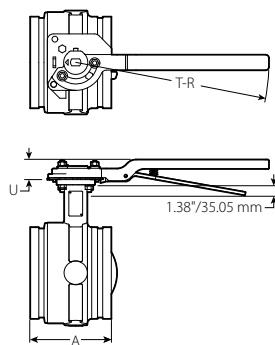

VALVE WITH LEVER LOCK HANDLE
AND MEMORY STOP
8”/200 MM SIZES

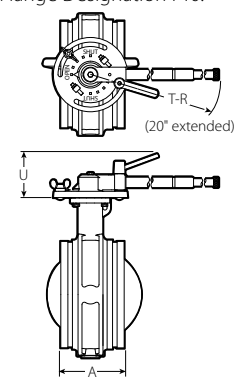

VALVE WITH LEVER LOCK HANDLE
AND MEMORY STOP
10 & 12”/250 & 300 MM SIZES

VIC[®]-300 MasterSeal[™] Butterfly Valves

SERIES 761

DIMENSIONS

With Gear Operator

Size		Dimensions – Inches/millimeters										Approx. Wgt. Ea.
Nominal Size In./mm	Actual Outside Diameter In./mm	A End to End	D	E	F	T	U	V	W	X	Y	Valve with Gear Operator Lbs./kg
2 50	2.375 60.3	3.21 81.5	—	—	8.65 219.7	1.57 40.0	4.76 121.0	6.84 173.8	1.89 48.0	3.64 92.5	3.9 100.0	6.0 2.7
2½ 65	2.875 73.0	3.77 95.8	—	—	9.38 238.3	1.57 40.0	4.76 121.0	7.28 185.0	1.89 48.0	3.64 92.5	3.9 100.0	7.5 3.4
76.1 mm	3.000 76.1	3.77 95.8	—	—	9.38 238.3	1.57 40.0	4.76 121.0	7.28 185.0	1.89 48.0	3.64 92.5	3.9 100.0	7.5 3.4
3 80	3.500 88.9	3.77 95.8	—	—	9.88 251	1.57 40.0	4.76 121.0	7.53 191.3	1.89 48.0	3.64 92.5	3.9 100.0	8.5 3.9
4 100	4.500 114.3	4.63 117.6	—	—	11.16 283.5	1.57 40.0	4.76 121.0	8.28 210.4	1.89 48.0	3.64 92.5	3.9 100.0	11.8 5.4
139.7mm	5.500 139.7	5.88 149.4	—	—	13.15 334.1	1.97 50.0	7.20 183.0	9.81 249.3	2.20 56.0	4.43 112.5	4.9 125.0	20.8 9.4
5 125	5.563 141.3	5.88 149.4	—	—	13.15 334.1	1.97 50.0	7.20 183.0	9.81 249.3	2.20 56.0	4.43 112.5	4.9 125.0	20.8 9.4
165.1 mm	6.500 165.1	5.88 149.4	0.41 10.5	—	14.14 359.2	1.97 50.0	7.20 183.0	10.31 262.0	2.20 56.0	4.43 112.5	4.9 125.0	24.0 10.9
6 150	6.625 168.3	5.88 149.4	0.41 10.5	—	14.14 359.2	1.97 50.0	7.20 183.0	10.31 261.9	2.28 57.9	4.43 112.5	4.9 125.0	24.0 10.9
8 200	8.625 219.1	5.33 135.4	1.47 37.4	0.8 20.4	16.63 422.5	1.97 50.0	7.20 183.0	11.56 293.7	2.20 56.0	4.43 112.5	4.9 125.0	38.3 17.4
10 250	10.750 273.0	6.40 162.6	1.81 45.9	1.41 35.7	21.55 547.4	2.87 73.0	8.98 228.0	15.18 385.7	3.11 79.0	6.30 160.0	7.9 200.0	81.5 39.0
12 300	12.750 323.9	6.50 165.1	2.79 70.9	2.29 58.3	23.54 598	2.87 73.0	8.98 228.0	16.18 411.1	3.11 79.0	6.30 160.0	7.9 200.0	97.5 44.2

† Contact Victaulic for availability.

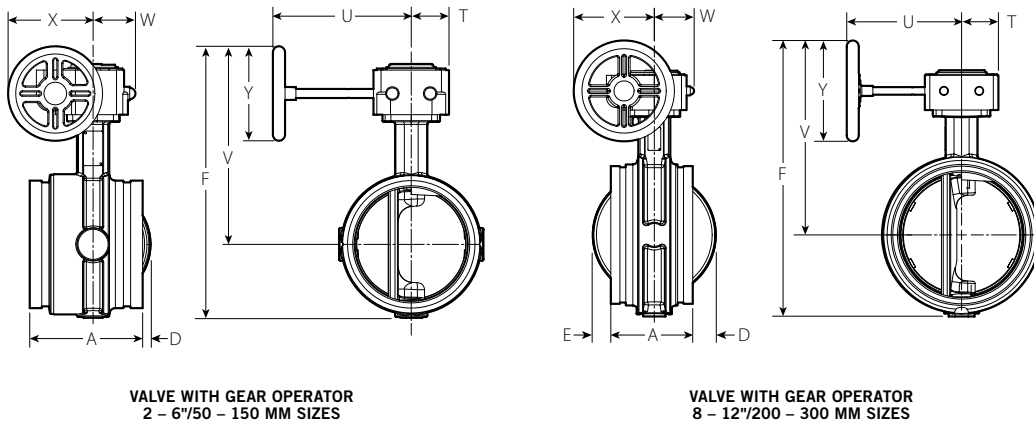

VIC®-300 MasterSeal™ Butterfly Valves

SERIES 761

ACCESSORIES

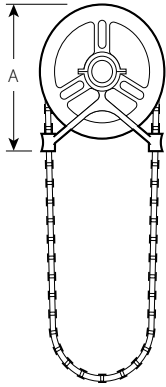

CHAIN WHEEL AND GUIDE WITH SAFETY CABLE KIT

Chain wheels are mounted to the gear operator handwheels. Sprocket rim and guide arms are made of cast aluminum. Chain is galvanized steel.

HOW TO ORDER:

Specify type valve and operator by valve numbering system shown on back page.

Always specify length of chain required.

For insulation and locking device, contact Victaulic for details. Hand Wheel Input Shaft Extensions are not for use with Chain Wheels.

Size	Dimensions – Inches/millimeters			Aprx. Wgt. Ea
Nominal Size In./mm	Sprocket Size	Chain Wheel Size (Dia.)	A	Lbs./kg
2 – 4 50 – 100	0	4.00 10	4.63 118	2.0 0.9
5 – 8 125 – 200	1	5.75 146	6.38 162	4.0 1.8
10 – 12 250 – 300	2	9.00 229	10.50 267	10.0 4.5

VIC®-300 MasterSeal™ Butterfly Valves

SERIES 761

FLOW CHARACTERISTICS

Flowchart - C_v

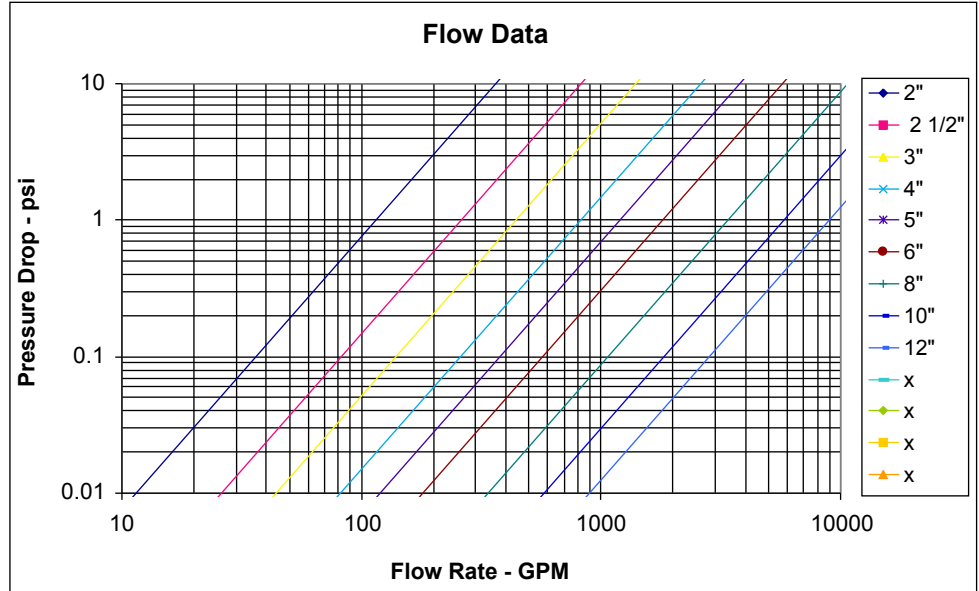

Flowchart - K_v

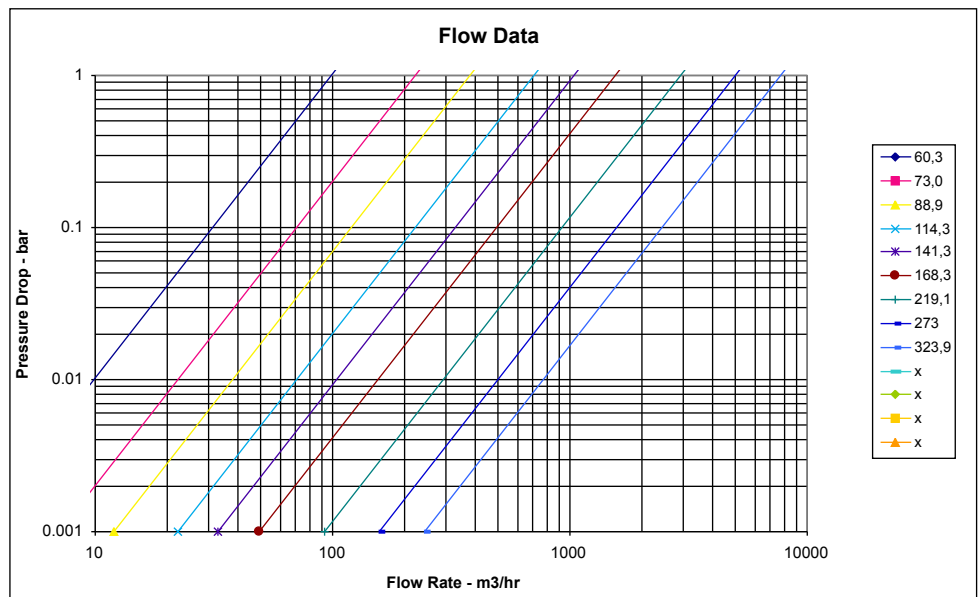

VIC®-300 MasterSeal™ Butterfly Valves

SERIES 761

PERFORMANCE

C_v values for flow of water at +60°F/+16°C with various disc positions are shown in the table below. Some of the following values are estimated. For exact values, please contact Victaulic for details.

Formulas for C_v Values:

$$\Delta P = \frac{Q^2}{C_v^2}$$

$$Q = C_v \times \sqrt{\Delta P}$$







Where:

Q = Flow (GPM)

ΔP = Pressure Drop (psi)

C_v = Flow Coefficient

Size		C _v	K _v	Size		C _v	K _v	Size		C _v	K _v	Size		C _v	K _v
Nom. Size In./mm	Actual Outside Dia. In./mm	(Full Open)	(Full Open)	Nom. Size In./mm	Actual Outside Dia. In./mm	(Full Open)	(Full Open)	Nom. Size In./mm	Actual Outside Dia. In./mm	(Full Open)	(Full Open)	Nom. Size In./mm	Actual Outside Dia. In./mm	(Full Open)	(Full Open)
2 50	2.375 60.3	115	99	4 100	4.500 114.3	820	707	139.7 mm	5.500 139.7	1200	1034	8 200	8.625 219.1	3400	2931
2½ 65	2.875 73.0	260	224	108.0 mm	4.250 108.0	820	707	6 150	6.625 168.3	1800	1552	10 250	10.750 273.0	5800	5000
76.1 mm	3.000 76.1	260	224	5 125	5.563 141.3	1200	1034	159.0 mm	6.250 159.0	1800	1552	12 300	12.750 323.9	9000	7758
3 80	3.500 88.9	440	379	133.0 mm	5.250 133.0	1200	1034	165.1 mm	6.500 165.1	1800	1552				

Size		FLOW COEFFICIENTS – C _v											
Nominal Size In./mm	Actual Outside Dia. In./mm	Disc Position (Degrees open)											
		90		70		60		50		40		30	
													
		C _v	K _v	C _v	K _v	C _v	K _v	C _v	K _v	C _v	K _v	C _v	K _v
2 50	2.375 60.3	115	99	60	52	36	31	23	20	14	12	7	6
2½ 65	2.875 73.0	260	224	140	121	80	69	50	43	30	26	16	14
76.1 mm	3.000 76.1	260	224	140	121	80	69	50	43	30	26	16	14
3 80	3.500 88.9	440	379	230	198	140	121	90	78	50	43	26	22
108.0 mm	4.250 108.0	820	707	430	371	250	216	160	138	100	86	50	43
4 100	4.500 114.3	820	707	430	371	250	216	160	138	100	86	50	43
133.0 mm	5.250 133.0	1200	1034	620	534	370	319	240	207	140	121	70	60
139.7 mm	5.500 139.7	1200	1034	620	534	370	319	240	207	140	121	70	60
5 125	5.563 141.3	1200	1034	620	534	370	319	240	207	140	121	70	60
159.0 mm	6.250 159.0	1800	1552	940	810	560	483	360	310	220	190	110	95
165.1 mm	6.500 165.1	1800	1552	940	810	560	483	360	310	220	190	110	95
6 150	6.625 168.3	1800	1552	940	810	560	483	360	310	220	190	110	95
8 200	8.625 219.1	3400	2931	1770	1526	1050	905	670	578	410	353	200	172
10 250	10.750 273.0	5800	5000	3020	2603	1800	1552	1150	991	700	603	350	302
12 300	12.750 323.9	9000	7758	4680	4034	2790	2405	1780	1534	1080	931	540	465

VIC[®]-300 MasterSeal[™] Butterfly Valves

SERIES 761

VALVE TORQUE REQUIREMENTS

Vic-300 MasterSeal valves have low torque requirements for operating the valve. This results in less manual effort, smaller gear operators or smaller actuators to open and close the valve.

Size		Torque – Inch Pounds/Newton Meters					
Nominal Size In./mm	Actual Outside Dia. In./mm	*Differential Pressure – psi/Bar					
		50/3	100/7	150/10	200/14	232/16	300/21
2 50	2.375 60.3	53 6.0	65 7.0	78 9.0	90 10.0	100 11.0	115 13.0
2½ 65	2.875 73.0	100 11.0	120 14.0	140 16.0	160 18.0	170 19.0	200 23.0
76.1 mm	3.000 76.1	100 11.0	120 14.0	140 16.0	160 18.0	170 19.0	200 23.0
3 80	3.500 88.9	150 17.0	170 19.0	190 22.0	210 24.0	230 26.0	260 29.0
108.0 mm	4.250 108.0	220 25.0	250 28.0	280 32.0	310 35.0	330 37.0	370 42.0
4 100	4.500 114.3	220 25.0	250 28.0	280 32.0	310 35.0	330 37.0	370 42.0
133.0 mm	5.250 133.0	340 38.0	390 44.0	450 51.0	500 57.0	530 60.0	600 68.0
139.7 mm	5.500 139.7	340 38.0	390 44.0	450 51.0	500 57.0	530 60.0	600 68.0
5 125	5.563 141.3	340 38.0	390 44.0	450 51.0	500 57.0	530 60.0	600 68.0
159.0 mm	6.250 159.0	410 46.0	470 53.0	540 61.0	600 68.0	640 72.0	730 83.0
165.1 mm	6.500 165.1	410 46.0	470 53.0	540 61.0	600 68.0	640 72.0	730 83.0
6 150	6.625 168.3	410 46.0	470 53.0	540 61.0	600 68.0	640 72.0	730 83.0
8 200	8.625 219.1	540 61.0	680 77.0	820 93.0	950 107.0	1040 118.0	1230 139.0
10 250	10.750 273.0	1610 182.0	1920 217.0	2230 252.0	2530 286.0	2730 308.0	3150 356.0
12 300	12.750 323.9	2720 307.0	2880 325.0	3040 344.0	3190 360.0	3290 372.0	3510 397.0

VIC®-300 MasterSeal™ Butterfly Valves

SERIES 761

VALVE TORQUE REQUIREMENTS

Source:

These torque values were derived from test data with non-lubricated valves in water at ambient temperatures with EPDM seals. For other material and service conditions, apply a suitable service factor.

Torque Factors:

All torque values are for normal conditions (i.e. the valve is operated at least once a quarter, disc corrosion is expected to be minor, the media is clean and non-abrasive, and the chemical effects upon the elastomer are minor).

Typical fluid torque factors commonly used in the industry are:

Water: 1.0; Lubricated service: 0.8; Dry gases: Lubricated nitrile "T" seat seals are recommended for dry gases wherever chemically appropriate. See material torque factor below.

Material Torque Factors:

"E" = 1.0; "O" = 1.2; "T" = 0.8

Cycling Factor:

Torque will typically increase as the valve is cycled. A factor of 1.5 should be applied for the first 5000 cycles and another 1.5 applied for all additional cycles. The higher number should be used if there are more than one cycle per hour.

Actuation Factor:

There are no actuation safety factors applied. A factor consistent with the consequences of not actuating should be applied. A minimum factor of 1.2 is recommended for directly actuated valves and 1.5 for 3-way assemblies.

Combining Torque Factors:

When multiple torque factors apply, they are combined by multiplying them. Example: For an EPDM seal and a 5000 cycle factor the combined factor would be $1.0 \times 1.5 = 1.5$.

Note:

Under certain high flow conditions, the hydrodynamic torque can exceed the seating torque. Large butterfly valves are not recommended for use in a free discharge condition, such as filling an empty line with fluid at the full rated pressure.

Contact Victaulic for other services.

VIC[®]-300 MasterSeal[™] Butterfly Valves

SERIES 761

TYPICAL SPECIFICATIONS

Butterfly valves 2 – 12"/50 – 300mm shall be rated to 300psi/2068kPa and be both bi-directional and dead-end service capable to full rated pressure. Body material shall be ductile iron with blow-out proof stainless steel stems and electroless nickel coated ductile iron disc. Seat material shall be EPDM (or lubricated nitrile or fluoroelastomer) and have a full 360° continuous contact with the seating surface. Stem seals shall be of the same material grade as the seats. Disc shall be offset from the centerline of the stems and shall be connected to the stem without the use of fasteners or pins. Valve ends shall be grooved. Valve shall have standard ISO flange mounting for ease of actuation. Operators shall be as specified by choice in valve table. The standard handle valve 2 – 8"/50 – 200mm shall include latch lock, infinitely variable and memory stop features. Manufacturer – Victaulic – Vic-300 MasterSeal Valve or approved equal. Valve with EPDM seat is UL classified to ANSI/NSF 61.

VIC-300 VALVE NUMBERING SYSTEM

V - 040 - 76 1 S E - O

Type	In./mm	Size Code	Series	Body Material	Disc/Stem	Seat	Operator
V	2/50	020	76 -Iron/IPS	1 - Ductile Iron	S - Ductile Iron/416SS	E - EPDM	0 - Bare
	2½/65	024			B - Aluminum Bronze/416SS	T - Lubricated Nitrile	2 - 10-Position handle with memory stop
	76.1 mm	761			V - Thermal Barrier	O - Fluoro-elastomer	3 - Gear operator
	3/80	030			X - CF8M/416SS		4 - Lever lock with tamper resistant device (8"/200 mm)
	4/100	040					5 - Gear operator with memory stop
	108.0 mm	108					6 - Gear operator with chain wheel
	5/125	050				9 - Special *	7 - Gear operator with memory stop and chain wheel
	133.0 mm	133					8 - Gear operator with AWWA 2" square oper. nut
	139.7 mm	139					9 - Special*
	6/150	060					
	159.0 mm	159					
	165.1 mm	165					
	8/200	080					
10/250	100						
12/300	120						

NOTES:
* Details required with order